

Product datasheet

Dock leveler

Crawford DL6121T

ASSA ABLOY

ASSA ABLOY Entrance Systems

The global leader in
door opening solutions

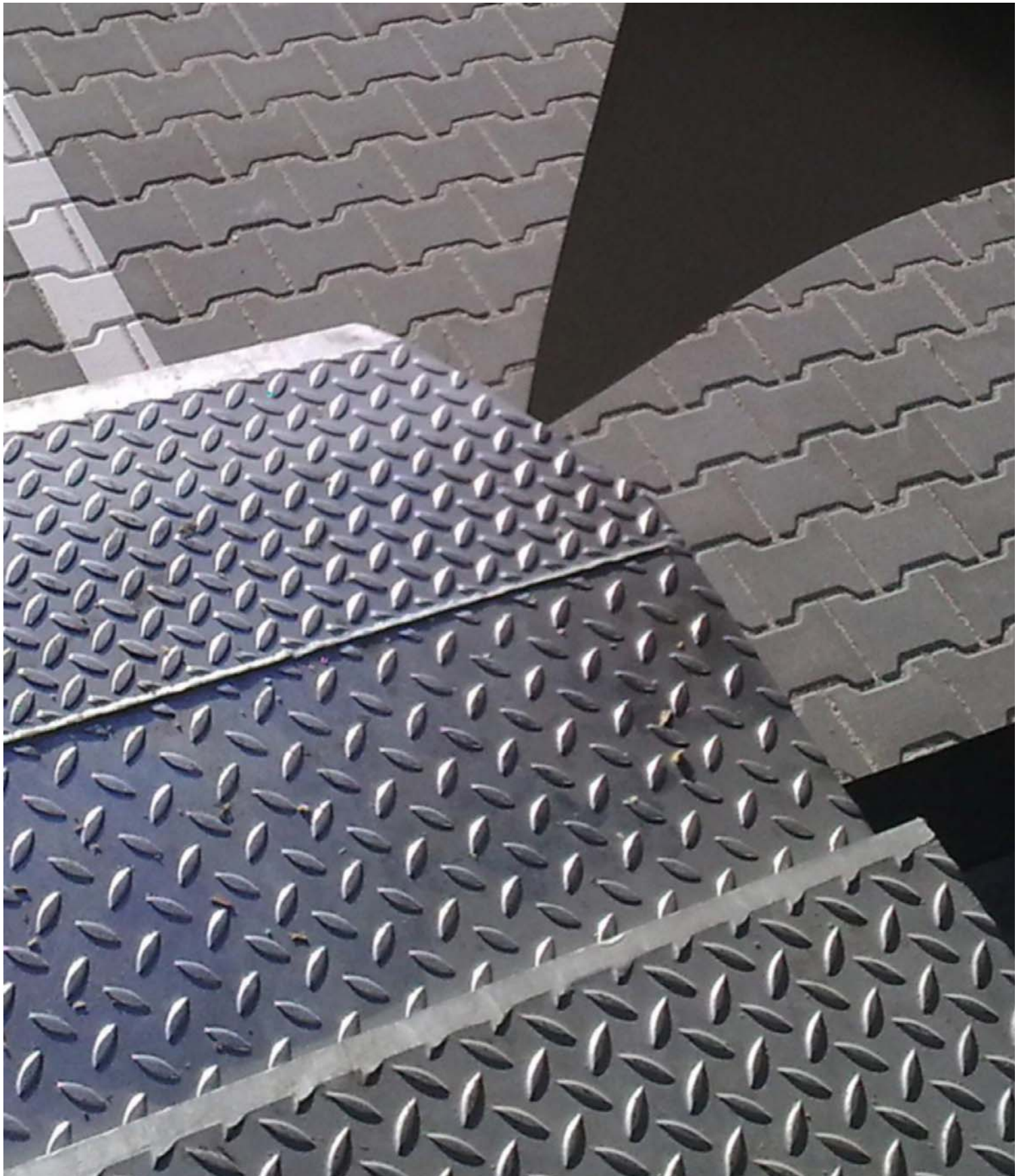

Copyright and Disclaimer Notice

Although the contents of this publication have been compiled with the greatest possible care, ASSA ABLOY Entrance Systems cannot accept liability for any damage that might arise from errors or omissions in this publication. We also reserve the right to make appropriate technical modifications/replacements without prior notice.

No rights can be derived from the contents of this document.

Color guides: Color differences may occur due to different printing and publication methods.

ASSA ABLOY, Besam, Crawford, Albany and Megadoor, as words and logos, are examples of trademarks owned by ASSA ABLOY Entrance Systems or companies within the ASSA ABLOY Group.

Copyright © ASSA ABLOY Entrance Systems AB 2006-2016.

No part of this publication may be copied or published by means of scanning, printing, photocopying, microfilm or any other process whatsoever without prior permission in writing by ASSA ABLOY Entrance Systems.

All rights reserved.

Technical facts

Features

	100kN	150kN
Sizes – leveler height	700, 800, 900 mm	700, 800 mm
Sizes – nominal length	2000, 2500, 3000, 3500, 4000, 4500 mm	2000, 2500, 3000 mm
Sizes – nominal width	2000, 2200 mm	2000, 2200 mm
Vertical working range - above dock	0 - 530	0 - 460
Vertical working range - below dock	0 - 440	0 - 390
Platform tear plate	8mm (8/10)	10mm (10/12)
Surface treatment	Standard: Option:	RAL 5010 RAL 3002 RAL 6005 RAL 9005 Hot dip galvanised
Control unit	Leveler control Door control Shelter control Fault & service indicator	

* Other sizes are available on request

Performance

	100kN	150kN
Load capacity	10 tonnes	15 tonnes
Max. point load	6,5 N/mm ²	6,5 N/mm ²
Motor hydraulic unit	1,5 kW	1,5 kW
Mains supply	400V 3-phase, 230V 3-phase	
Control unit protection class	IP54	
Allowable oil types	ASSA ABLOY standard hydraulic oil(-20°C - +60°C) ASSA ABLOY low temperature hydraulic oil (-30°C - +60°C) ASSA ABLOY bio hydraulic oil (-20°C - +60°C)	
Magnetic valves	24V/DC 18W S1	
Surface treatment paint class 1	80 µm Corrosive Category C2 M acc. DIN EN ISO 12944-2	
Surface treatment paint class 3	160 µm Corrosive Category C3 M acc. DIN EN ISO 12944-2	
Surface treatment galvanised	Hot dip galvanised 80 µm Corrosive category C4 & C5-I M acc. DIN EN ISO 12944-2	

Contents

Copyright and Disclaimer Notice	2
Technical facts	3
Contents	4
1. Description	6
1.1 General.....	6
1.1.1 Application.....	6
1.1.2 Mode of operation	6
1.1.3 Overview.....	6
1.1.4 Standard.....	6
1.1.5 Options.....	6
1.2 Telescopic Lip.....	7
1.2.1 Lip material	7
1.2.2 Lip shapes	7
1.3 Platform	7
1.3.1 Platform tear-plate thickness	7
1.3.2 EPDM seal	7
1.3.3 Slip protection / noise reduction	7
1.4 Surface.....	8
1.4.1 Painting	8
1.4.2 Hot galvanising.....	8
1.5 Frames - connection to building.....	8
1.5.1 T - leveler frame for embedding in concrete	8
1.5.2 W - leveler frame for welding	8
1.6 Docking control systems	9
1.6.1 950 Docking LA TD.....	9
1.6.2 950 Docking DLA TD	9
1.6.3 950 Docking LSA TD	9
1.6.4 950 Docking DLSA TD	9
1.7 Monitoring systems.....	10
1.7.1 Saving energy.....	10
1.7.2 Security enhancement	10
1.7.3 Dock management	10
1.7.4 Facility management	10
1.8 Equipment.....	10
1.8.1 Buffers.....	10
1.8.2 ASSA ABLOY DE6090E Eye	11
1.8.3 ASSA ABLOY DE6090WC Wheel chock	12
1.8.4 ASSA ABLOY DE6090TLS Traffic light system	12
1.8.5 ASSA ABLOY DE6090DL Dock light Heavy Duty LED	12
1.8.6 Parking guides.....	12
1.8.7 ASSA ABLOY DE6090DI Dock-IN Autodock	12

2.	Selection guide	14
2.1	Load capacity according to EN1398	14
2.1.1	Rated load	14
2.1.2	Axle load	14
2.1.3	Dynamic load	14
2.2	Select the load capacity	14
2.2.1	Example	14
2.3	Select the leveler length	14
2.3.1	The calculation	14
2.3.2	Example	14
2.4	Nominal width.....	14
2.5	Free space under lip.....	15
2.5.1	Steel lip.....	15
3.	Specifications	16
3.1	Dimensions.....	16
3.2	Platform thickness.....	16
3.3	Control units	17
3.3.1	Dimensions.....	17
3.3.2	Functions	17
4.	CEN Performance	18
4.1	Safety according to the European Standard EN 1398	18
5.	Building and space requirements	19
5.1	Electrical preparations.....	19
5.2	Pit preparations.....	20
5.2.1	T - frame	20
5.2.2	W - frame	20
5.2.3	B - frame.....	21
6.	Service	22
	Index	23

1. Description

1.1 General

1.1.1 Application

The Crawford DL6121T teledock is the optimal efficiency solution in general industry and logistics applications. The telescopic lip precisely bridges the gap between the ramp and the lorry bed. The Crawford DL6121T teledock system meets the standard demands of most loading operations and fully complies with rules and regulations of the European Standard EN 1398.

1.1.2 Mode of operation

The operation of the Crawford DL6121T teledock is based on an electro-hydraulic telescopic lip, controlled by a semi-automatic control unit.

When the dock leveler is raised, the lip extends and the leveler lowers gently onto the lorry bed. After loading or unloading, the leveler is raised again, the lip retracts and the platform returns to its parking position, i.e. to ramp level.

1.1.3 Overview

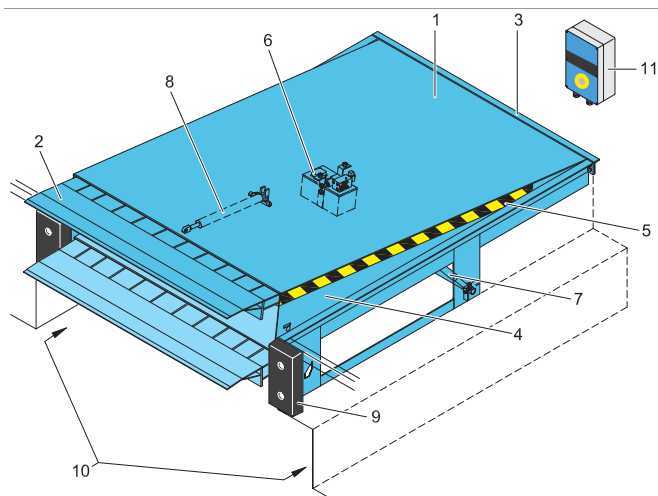

- 1) Leveler platform
- 2) Telescopic lip
- 3) Leveler frame
- 4) Side plates
- 5) Warning stripes
- 6) Hydraulic unit
- 7) Lift cylinders
- 8) Telescopic lip cylinder
- 9) Buffers (optional)
- 10) Tail lift recess
- 11) Control unit

1.1.4 Standard

Frames - connection to building:	T-frame (fishtails frame)
Surface	Painting RAL 5010
Hydraulic Equipment	Low noise hydraulic unit Two hydraulic lift cylinders One hydraulic lip cylinder
Lip	Lip length 500 mm Steel lip

1.1.5 Options

Frames - connection to building	W-frame [frame for welding] B-frame [box-frame]
Surface	Painting RAL 3002, RAL 6005 or RAL 9005 Hot dip galvanised
Hydraulic equipment	Low temperature oil Bio oil
Lip options	Lip length 1000 mm Tapered lip s = 125 mm
Energy & ergonomics	EPDM seal Slip protection/noise reduction

1.2 Telescopic Lip

1.2.1 Lip material

1.2.1.1 Steel telescopic lip

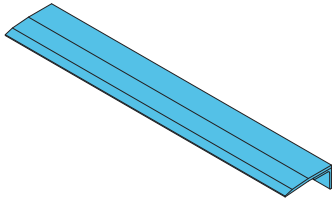

The steel telescopic lip is designed for use by heavy loading equipment. It has a high durability, while it provides medium comfort.

1.2.2 Lip shapes

1.2.2.1 Standard telescopic lip

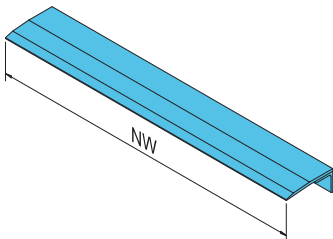

The standard telescopic lip is a single rectangular lip for use with a fleet of vehicles that is a standard size.

1.2.2.2 Tapered telescopic lip

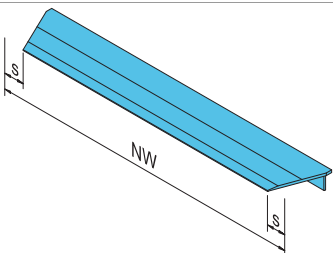

A tapered telescopic lip ensures that the lip reaches the lorry bed, even when the lorry is not parked in the exact centre position. Avoids damage to the truck and interruptions of the dock-in procedure.
 $s = 125 \text{ mm}$

1.3 Platform

1.3.1 Platform tear-plate thickness

The 10 mm (10/12) tear-plate is designed for loading and unloading with typical 4 wheel pneumatic-tired fork-lift trucks, and is also suitable for handling equipment with high point loads, such as electric pallet trucks.

1.3.2 EPDM seal

To seal the gap between leveler and pit, an EPDM seal can be factory-installed between the flexible platform and frame. By reducing draughts into the building, working conditions improve and energy savings increase.

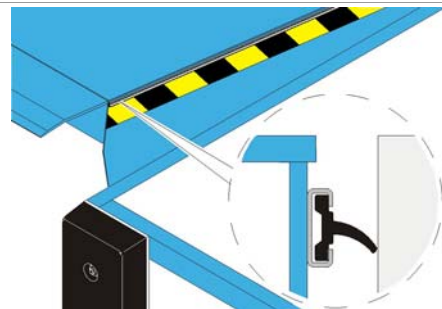

1.3.3 Slip protection / noise reduction

Applying a polyurethane slip protection coating on the lip and platform ensures a durable non-slip and noise reduction surface. The effect is a smooth and comfortable surface for handling equipment that is less receptive to wear and tear. The PU coating material is resistant to impact, to thermal impact and most types of chemicals and it has a high loading capacity.

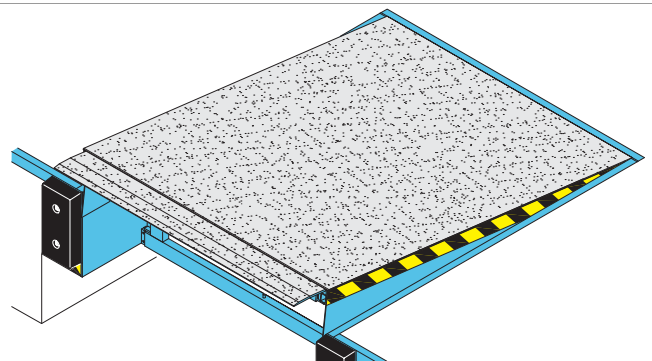

1.4 Surface

1.4.1 Painting

1.4.1.1 Colors

The dock leveler standard finish is painted. The standard color is:



Colours available as option are:

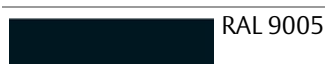

1.4.1.2 Standard paint class

If the dock leveler is to be used in a rural area, the standard finish is:

- Paint class 1; 80 µm factory painted for corrosive category C2 M

1.4.1.3 Paint classes

If the dock leveler is to be used in an urban or industrial atmosphere, or in a coastal area, it may be appropriate to select an alternative paint class with increased resistance to corrosion C3 M.

- Paint class 3; 160 µm factory painted for corrosive category C3 M

1.4.2 Hot galvanising

To increase corrosion protection to C4 for saline coastal areas or C5-I for aggressive or humid atmospheres, the dock leveler can be delivered with hot dip galvanised (80 µm) steel parts.

1.5 Frames - connection to building

The frame is the leveler's connection point to the building and a rigid support for the leveler.

The Crawford DL6121T teledock is available with different frame types. The frame can be embedded in concrete or installed via screws or welding. All frames are illustrated with the tail lift recess. The levelers are also available without tail lift recess.

1.5.1 T - leveler frame for embedding in concrete

The T-frame is installed in one step. The leveler is directly embedded in concrete.

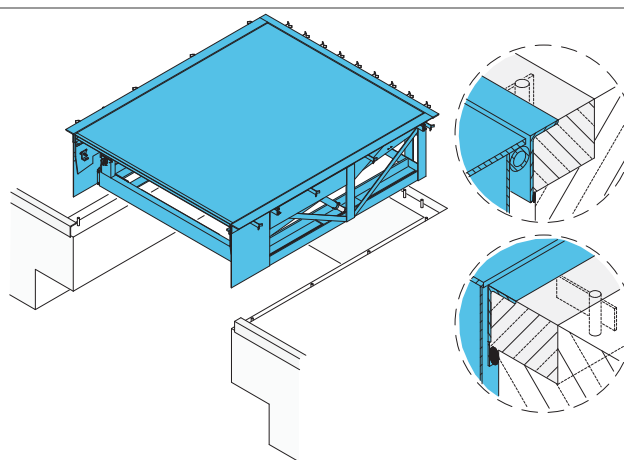

1.5.2 W - leveler frame for welding

The W-frame is designed to weld the leveler directly to the floor slab. In case of future replacement, the welding points can be ground away.

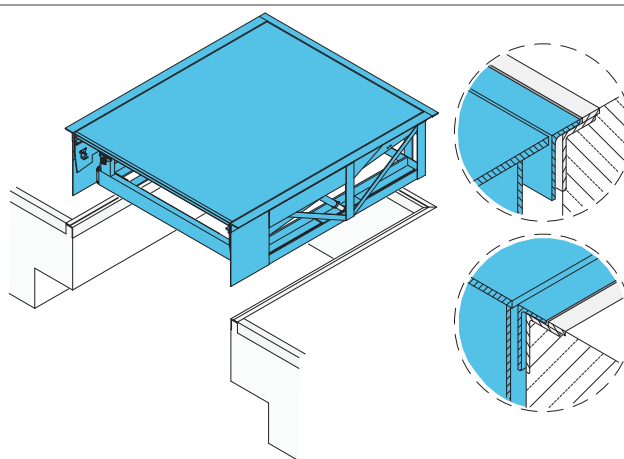

1.6 Docking control systems

1.6.1 950 Docking LA TD

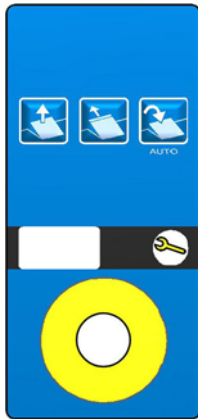

- Hold-to-run button to lift platform.
- Hold-to-run button to position the lip on the truck bed.
- Impulse auto button to put the leveler back in parking position.
- Mains isolator or emergency stop button.
- Interface to incorporate ASSA ABLOY Eye and/or wheel chock.

1.6.3 950 Docking LSA TD

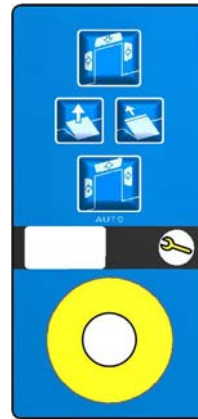

- Hold-to-run button to lift platform.
- Hold-to-run button to position the lip on the truck bed.
- Impulse auto button to put the leveler back in parking position.
- Mains isolator or emergency stop button.
- Interface to incorporate ASSA ABLOY Eye and/or wheel chock.
- Designed to operate an inflatable shelter in the docking station.

1.6.2 950 Docking DLA TD

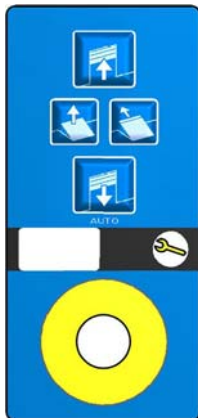

- Hold-to-run button to lift platform.
- Hold-to-run button to position the lip on the truck bed.
- Impulse auto button to put the leveler back in parking position.
- Mains isolator or emergency stop button.
- Interface to incorporate ASSA ABLOY Eye and/or wheel chock.
- Designed to operate an overhead sectional door in the docking station.

1.6.4 950 Docking DLSA TD

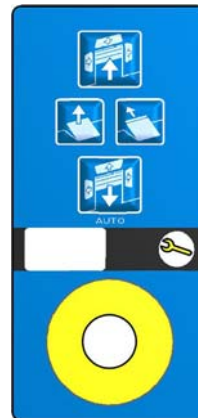

- Hold-to-run button to lift platform.
- Hold-to-run button to position the lip on the truck bed.
- Impulse auto button to put the leveler back in parking position.
- Mains isolator or emergency stop button.
- Interface to incorporate ASSA ABLOY Eye and/or wheel chock.
- Designed to operate an overhead sectional door and an inflatable shelter in the docking station.

1.7 Monitoring systems

As an option on all our products, an ASSA ABLOY Monitoring System can be installed. This system helps to ensure efficiency and security in daily operations. All doors or docking stations are connected to the Monitoring System's server, which gives the opportunity to supervise, monitor and report a wide variety of aspects in a facility.



1.7.1 Saving energy

A monitoring system reduces energy costs and contributes to a better environment. Energy is lost every time a door is open. If a door is open when no truck is at the bay, even more energy is lost.

An ASSA ABLOY Monitoring System automatically ensures that no door will open unless there is a truck at the bay and even set it to close when there an activity is delayed.

1.7.2 Security enhancement

Closing and locking doors is an obvious daily routine. However, checking this manually can be time consuming in a busy facility.

An ASSA ABLOY Monitoring System can automatically ensure that all doors are closed and locked when they need to be. It can also activate all doors and locks from its remote location, and give a real-time overview of the building's situation.

1.7.3 Dock management

A good way to increase throughput and thereby efficiency at a logistics facility is to reduce the time of having no truck – or the wrong truck – at a loading bay.

An ASSA ABLOY Monitoring System makes visible – in real-time – which bays are occupied or free, and for how long. It makes it possible to reserve bays for docking activities and to inform drivers via SMS. Since it incorporates information from cameras and other inputs (RFID, card readers, etc.), the system stays updated in real-time.

1.7.4 Facility management

The ASSA ABLOY Monitoring System gives a real-time service status for all your door and docking equipment. If an error code occurs, the ASSA ABLOY Entrance Systems service organisation is automatically notified, and will respond quickly. Other maintenance information can easily be integrated, further reducing the overall costs.

1.8 Equipment

1.8.1 Buffers

Buffers placed in front of the dock leveler absorb the energy of a vehicle that accidentally or intentionally hits the building. Buffers are available in various sizes, in fixed or moving models, and with rubber finishing or steel plate and spring function.

1.8.1.1 RS

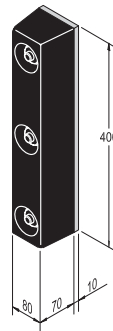

Application

The RS buffer is the economical solution for docking stations where vehicles of equal sizes load and unload.

1.8.1.2 RB

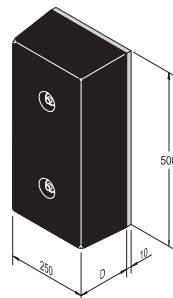

Application

The RB buffer is a large fixed rubber. It is the universal building and vehicle protection solution.

Available depths:

- 90 mm
- 140 mm

1.8.1.3 RB with steel front plate

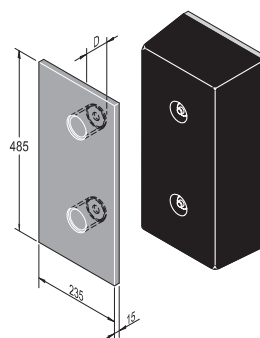

Application

The RB buffer with steel protection front plate increases the building protection and the buffer service life.

Available depths:

- 90 mm
- 140 mm

1.8.1.4 RB with steel front and top plate

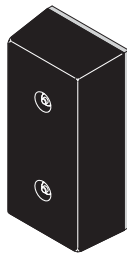
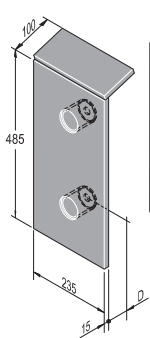

Application

The RB buffer with steel protection front and top plate is designed for vehicles with high lorry beds like interchangeable open bodies and containers.

Available depths:

- 90 mm
- 140 mm

1.8.1.5 RB with steel construction

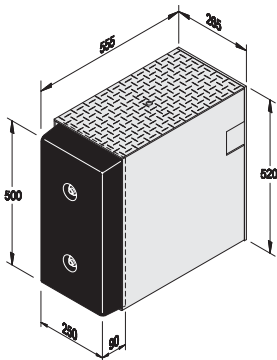

Application

The RB buffer with steel construction is designed to create a security gap between your dock leveler with 1000mm telescopic lip and the truck.

1.8.1.6 RB with steel construction and steel front plate

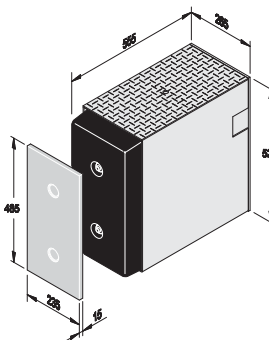

Application

The RB buffer with steel construction is designed to create a security gap between your dock leveler with 1000mm telescopic lip and the truck. The steel protection front plate increases the building protection and the buffer service life.

1.8.1.7 EBH

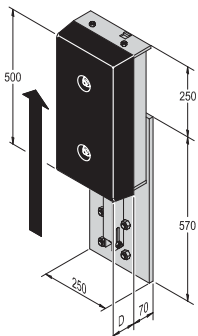

Application

The EBH buffer is the ideal solution for docking stations where vehicles of notable height differences load and unload. This buffer can be vertically adjusted by a 'release device'.

Available depths:

- 90 mm
- 140 mm

1.8.1.8 EBF

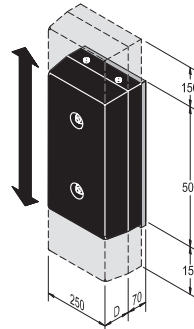

Application

The EBF buffer is the ideal solution for docking stations where vehicles are expected to make notable vertical suspension changes when loading or unloading. This buffer follows vertical movements of the vehicle.

Available depths:

- 90 mm
- 140 mm

1.8.1.9 Steel spring buffer 800

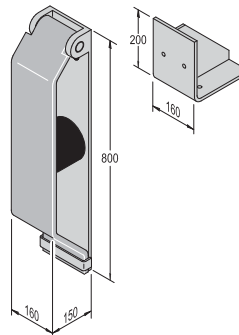

Application

The 800 mm steel spring buffer is designed for applications where vehicles generally are higher than ramp level.

1.8.1.10 Steel spring buffer 600

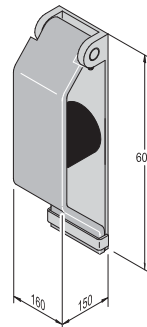

Application

The steel spring buffer is the ideal protector of the ramp as well as the vehicle itself.

1.8.2 ASSA ABLOY DE6090E Eye

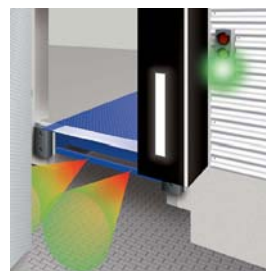

The ASSA ABLOY Eye is an electronic, sensor-based dock-in system, which measures the distance between the vehicle and the building. This makes it easier for the driver to complete the dock-in procedure, but also detects objects or people behind the vehicle.

1.8.3 ASSA ABLOY DE6090WC Wheel chock

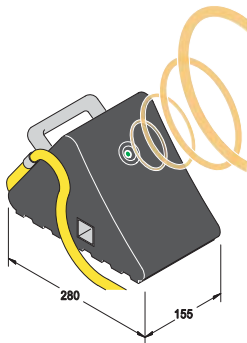

The wheel chock has a sensor to detect the presence and position of the vehicle and is connected to the dock leveler control panel. If no vehicle is detected, the docking station is blocked for safety reasons. Furthermore, the wheel chock prevents the vehicle from moving during loading/unloading.

1.8.4 ASSA ABLOY DE6090TLS Traffic light system



The traffic light system either has a sensor above the dock leveler that measures the presence of the vehicle or it is a wheel chock that detects the vehicle.

If there is no vehicle (dock leveler is free), the traffic light inside is red, outside is green.

The traffic light can also be combined with a wheel chock, ASSA ABLOY Eye or door/leveler interlocking.

1.8.5 ASSA ABLOY DE6090DL Dock light Heavy Duty LED

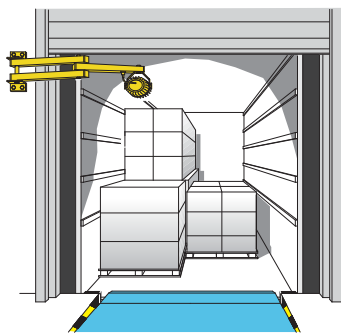

Where dock lights are often a vulnerable object in the docking area, the virtually indestructible Dock Light Heavy Duty LED is the perfect solution to bring light in the truck and docking area. It is designed for the most demanding environments and can withstand possible hard hits from a moving forklift without being damaged.

1.8.6 Parking guides

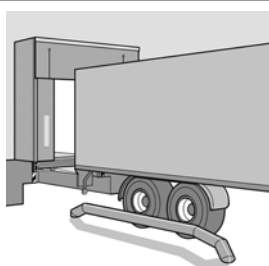

This visual aid makes it easier to park the vehicle and reduces the risk of collision. Especially advantageous for docking stations with wide leveler lips and cushion shelters. Parking guides can be bolted or cast in concrete on the floor before the leveler.

1.8.7 ASSA ABLOY DE6090DI Dock-IN Autodock

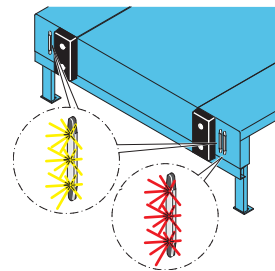

ASSA ABLOY Dock-IN offers a complete line of guide- and traffic lights that align the truck with the docking bay to make the dock-in procedure easy and safe. ASSA ABLOY Dock-IN is based on modern LED technology and stands for high reliability and low energy consumption.

1.8.7.1 Dock-IN White

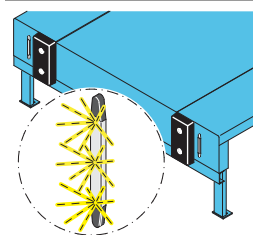

ASSA ABLOY Dock-IN White consists of two white LED light bars. It is designed to help guide a truck to the dock. ASSA ABLOY Dock-IN White offers much more visual aid than white stripes on the shelter or asphalt. Mounted on the wall they are always clearly visible, less exposed to wear and tear and not hidden by dirt and snow!

1.8.7.2 Dock-IN Red

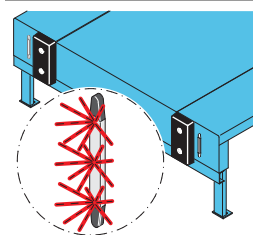

ASSA ABLOY Dock-IN Red is a traffic light system consisting of one red LED light bar, a sensor for truck detection and a traffic light control box. The sensor detects the truck when it is in the right position, very close to the dock. The red LED turns ON to give the signal to the truck driver to break and let the truck roll against the buffer at the lowest speed, without the risk of damage. The system includes interlocking of the loading bay control box functions which are only released when the truck is in place and the red LED is ON.

1.8.7.3 Dock-IN White & Red

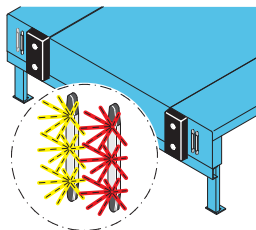

ASSA ABLOY Dock-IN White & Red is the optimum combination of both systems for easy and safe docking. The white LEDs provide the visual target and the red LED positions the truck at the right distance to the dock. The white guiding LEDs turn off when the truck is detected and at the same time the red LED turns ON. ASSA ABLOY Dock-IN White & Red guide the truck driver in the best possible way for an easy and safe docking.

1.8.7.4 Available Options

- Indication Light Inside, built into the 950 control box
A Green LED light on the control box to indicate that the control box functions are released. The operator of the loading bay equipment knows exactly when he can start loading or unloading. The green LED light will help to save energy and to control the complete loading process.
- Second Red LED
A second Red LED bar can be added to have the red LED traffic light on both sides of the docking bay. This is an option for terminals with left and right hand drive international trucks.
- Wheel chock connection
To increase the safety it is possible to connect the ASSA ABLOY wheel chock to the traffic light function ASSA ABLOY Dock-IN Red or ASSA ABLOY Dock-IN White and Red. The control box will be interlocked until the truck is detected and the wheel chock is in place.

Note:

Make sure the LED bars will not be covered by the Dock shelter.

Lowest possible truck is max. 2000 mm below the sensor position.

2. Selection guide

2.1 Load capacity according to EN1398

The EN 1398 describes 3 key definitions about loads.

2.1.1 Rated load

The rated load is the total weight of the goods, the forklift truck and the driver.



2.1.2 Axle load

Axle loads shall be taken acting over two rectangular contact areas at 1 m lateral distance. These areas shall only apply if the actual conditions do not call for more severe loading. The size of the footprint [mm²] is derived from the wheel load [N] divided by 2 [N/mm²]. The ratio of the rectangular print is W:L = 3:2.

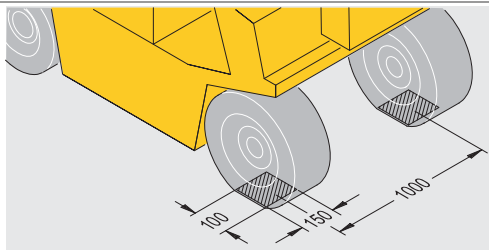

In the drawing measures for a leveler with a load capacity of 100kN or 150kN are shown.

2.1.3 Dynamic load

The dynamic load is the movement of the rated load and is the pressure on the leveler platform caused by the moving forklift truck.



2.2 Select the load capacity

The load capacity of a dock leveler must always be higher than the rated load.

2.2.1 Example

	100kN	150kN
Weight of forklift truck	5000 kg	8000 kg
Weight of goods	3500 kg	6500 kg
Weight of driver	100 kg	100 kg
Total weight/rated load	8600 kg	14600 kg
Suitable load capacity of the leveler	10000 kg/ 100kN	15000 kg/ 150kN

2.3 Select the leveler length

When determining the leveler length, measure the maximum height difference between the truck bed and the dock level. Next, determine which vehicles will be used and lookup the maximum gradient the vehicles are allowed to be used on.

Vehicle	Max gradient
Roll cage	3%
Hand pallet truck	3%
Electric pallet truck	7%
Forklift truck (battery)	10%
Forklift truck (gas / petrol)	15%

2.3.1 The calculation

Minimal leveler length = height difference / gradient (%)

2.3.2 Example

Vehicle:	Electric pallet truck (max 7% gradient)
Truck height:	1350 – 1000 mm
Dock height:	1150 mm

The difference between Truck height and Dock height = 175 mm

175 mm / 7% = 2500 mm leveler length

2.4 Nominal width

The Crawford DL6121T teledock is available with a nominal width of 2000 mm or 2200 mm. The correct nominal width must exceed the widest loading vehicle by at least 700 mm.

2.5 Free space under lip

2.5.1 Steel lip

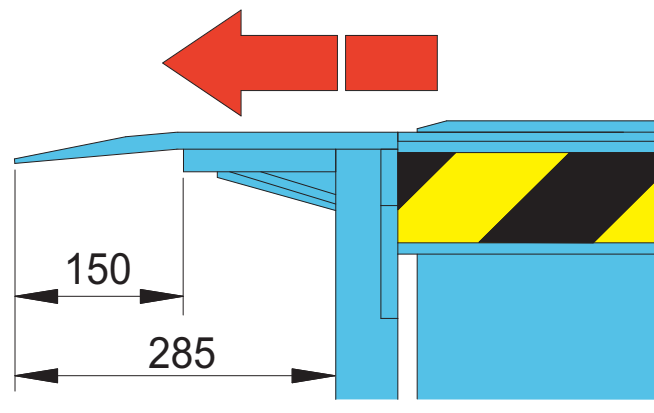

3. Specifications

3.1 Dimensions

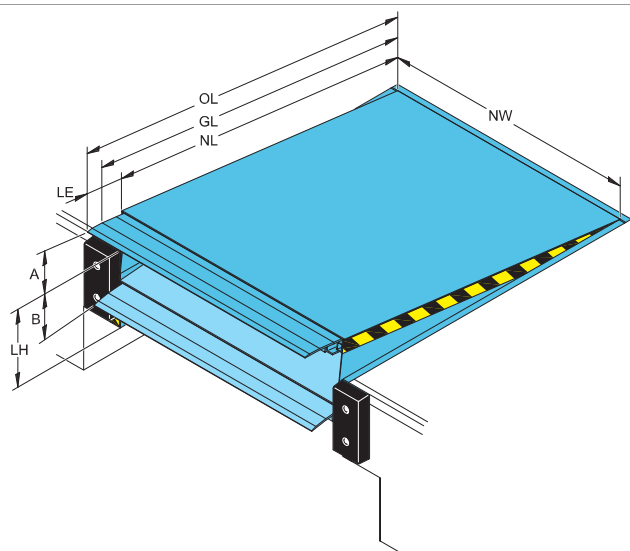

NL	Nominal length
OL	Overall length
GL	Gradient length
NW	Nominal width
LE	Lip extension
LH	Leveler height
A	Working range above dock level
B	Working range below dock level

Dimensions	Vertical working range
	100kN

LE 500 mm LE 1000mm

NL	OL	GL	LH	A	B	A	B
2000	NL + LE	NL+(LE-150)	700	290	340	360	410
2500	NL + LE	NL+(LE-150)	700	280	340	330	390
3000	NL + LE	NL+(LE-150)	800	370	390	440	440
3500	NL + LE	NL+(LE-150)	900	440	380	510	420
4000	NL + LE	NL+(LE-150)	900	460	410	510	410
4500	NL + LE	NL+(LE-150)	900	480	370	530	400

Nominal Width (NW) : 2000, 2200 mm.

Dimensions	Vertical working range
	150kN

LE 500 mm LE 1000mm

NL	OL	GL	LH	A	B	A	B
2000	NL + LE	NL+(LE-150)	700	260	340	330	390
2500	NL + LE	NL+(LE-150)	700	330	310	400	350
3000	NL + LE	NL+(LE-150)	800	390	360	460	390

Nominal Width (NW) : 2000, 2200 mm.

3.2 Platform thickness

Thickness	Max. point load
8mm (8/10)	6,5 N/mm ²
10mm (10/12)	6,5 N/mm ²

3.3 Control units

3.3.1 Dimensions



950 Series

3.3.2 Functions

Functions included	LA-TD	DSA-TD	LSA-TD	DLSA-TD
Hold to run button	<input checked="" type="checkbox"/>	<input checked="" type="checkbox"/>	<input checked="" type="checkbox"/>	<input checked="" type="checkbox"/>
Close (hold to run)	<input checked="" type="checkbox"/>	<input checked="" type="checkbox"/>	<input checked="" type="checkbox"/>	<input checked="" type="checkbox"/>
Impulse auto button	<input checked="" type="checkbox"/>	<input checked="" type="checkbox"/>	<input checked="" type="checkbox"/>	<input checked="" type="checkbox"/>
Extend lip (hold to run)	<input checked="" type="checkbox"/>	<input checked="" type="checkbox"/>	<input checked="" type="checkbox"/>	<input checked="" type="checkbox"/>
Mains isolator	<input checked="" type="checkbox"/>	<input checked="" type="checkbox"/>	<input checked="" type="checkbox"/>	<input checked="" type="checkbox"/>
Emergency stop button	<input type="checkbox"/>	<input type="checkbox"/>	<input type="checkbox"/>	<input type="checkbox"/>
400V	<input checked="" type="checkbox"/>	<input checked="" type="checkbox"/>	<input checked="" type="checkbox"/>	<input checked="" type="checkbox"/>
230V	<input type="checkbox"/>	<input type="checkbox"/>	<input type="checkbox"/>	
Maintenance indicator	<input checked="" type="checkbox"/>	<input checked="" type="checkbox"/>	<input checked="" type="checkbox"/>	<input checked="" type="checkbox"/>
3 Digit display	<input checked="" type="checkbox"/>	<input checked="" type="checkbox"/>	<input checked="" type="checkbox"/>	<input checked="" type="checkbox"/>
Memory function	<input checked="" type="checkbox"/>	<input checked="" type="checkbox"/>	<input checked="" type="checkbox"/>	<input checked="" type="checkbox"/>
Connection to ASSA ABLOY Monitoring System	<input type="checkbox"/>	<input type="checkbox"/>	<input type="checkbox"/>	<input type="checkbox"/>
BUS network interface	<input type="checkbox"/>	<input type="checkbox"/>	<input type="checkbox"/>	<input type="checkbox"/>
ASSA ABLOY eye	<input type="checkbox"/>	<input type="checkbox"/>	<input type="checkbox"/>	<input type="checkbox"/>
Wheel chock	<input type="checkbox"/>	<input type="checkbox"/>	<input type="checkbox"/>	<input type="checkbox"/>
Door control		<input checked="" type="checkbox"/>		<input checked="" type="checkbox"/>
Shelter control			<input checked="" type="checkbox"/>	<input checked="" type="checkbox"/>

Standard

Option / Available

4. CEN Performance

4.1 Safety according to the European Standard EN 1398

- Emergency Stop Function.
 - Safety valves block lowering movement after max. 6% of the nominal length of the leveler.
 - Two lift cylinders make sure the leveler stops in a horizontal position.
- Free floating position.
- Platform torsion. Lateral deflection of at least 3% of nominal width.
- Toe guards cover gap between platform and pit in leveler's highest position.
- Working range gradient max. 12,5% (~7°).
- Warning stripes on side plates and on frame (black/yellow).

5. Building and space requirements

5.1 Electrical preparations

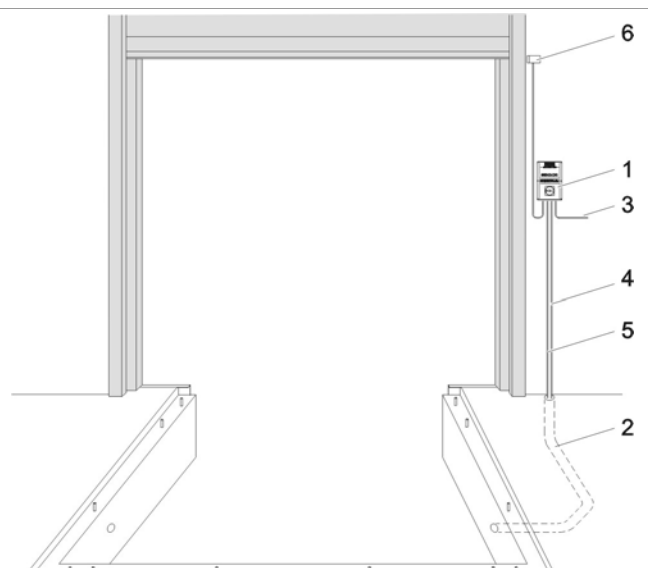

1	Control unit (included in the delivery)
2	Conduit for wiring internal diameter 70, angles <math><45^\circ</math> (by others)
3	Mains supply: 3/N/PE AC 50 Hz 400V 3-phase, 230V 3-phase Mains fuse: D0 10 A gL Motor power: 1,5 kW
4	Cable: 7 x 0,75 mm ²
5	Motor cable: 4 x 1,5 mm ²
6	Optional safety switch on sectional door to disable leveler when door is closed*

*Non standard

5.2 Pit preparations

This section illustrates the required pit preparations for each frame type for the Crawford DL6121T teledock.

5.2.1 T - frame

With tail lift recess

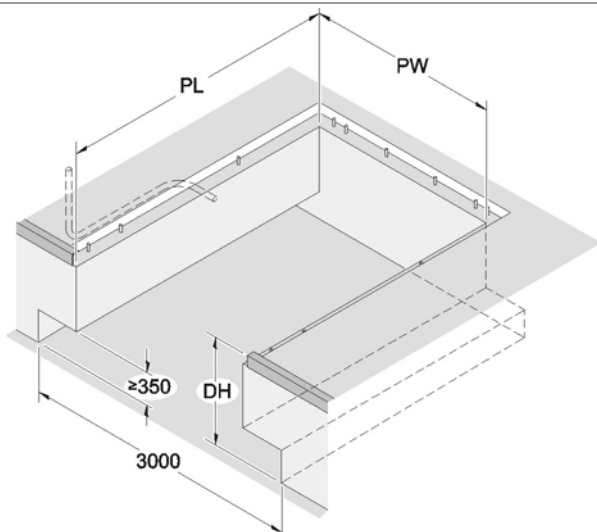

Pit drawing 51510019 for 100 kN

Pit drawing 51510013 for 150 kN

Without tail lift recess

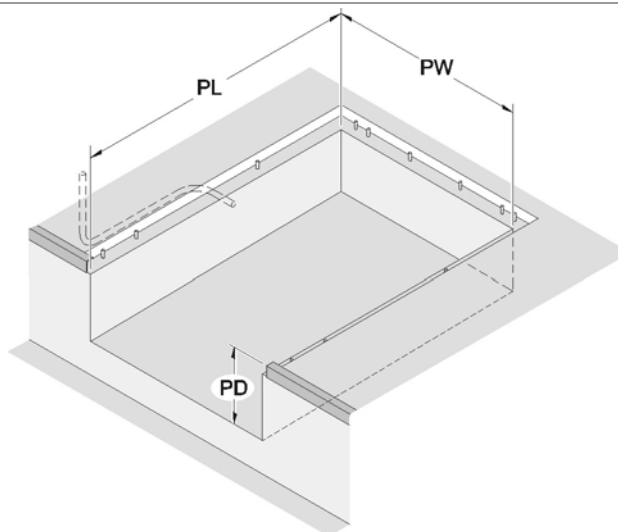

Pit drawing 51510022 for 100 kN

Pit drawing 51510016 for 150 kN

5.2.2 W - frame

With tail lift recess

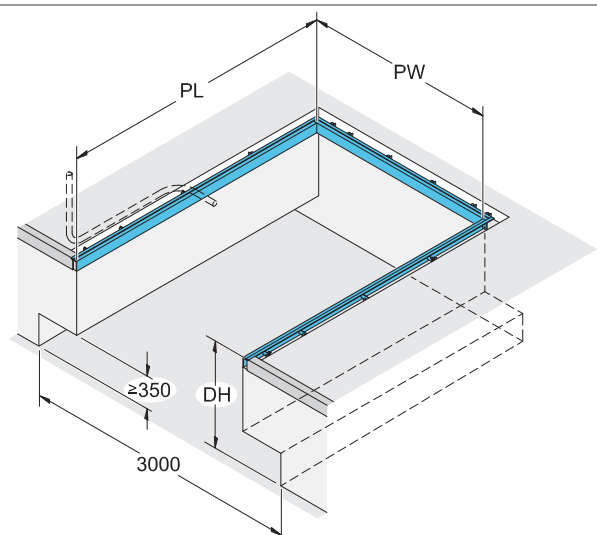

Pit drawing 51510020 for 100 kN

Pit drawing 51510014 for 150 kN

Without tail lift recess

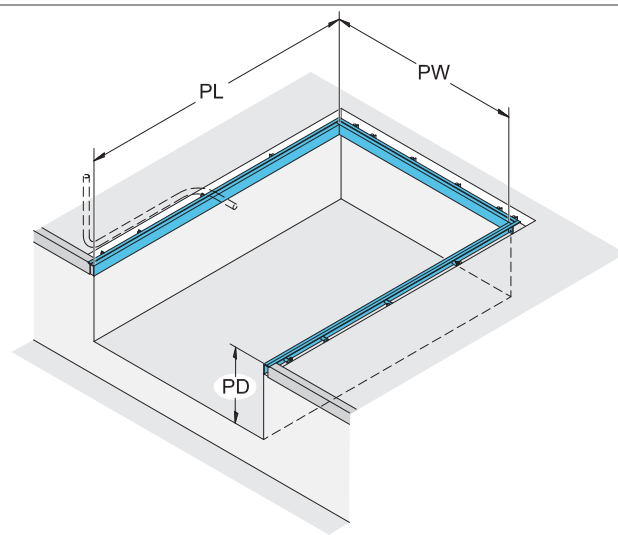

Pit drawing 51510023 for 100 kN

Pit drawing 51510017 for 150 kN

5.2.3 B - frame

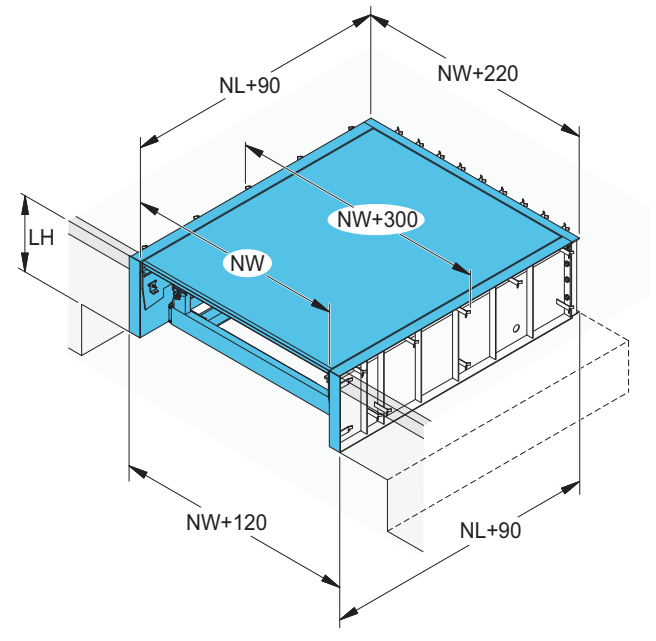

6. Service

Preventive Maintenance Program and Modernization Services

As your entrances are part of your business flow, there's every reason to keep them working well. ASSA ABLOY Entrance Systems offers you a maintenance and modernization expertise to rely on. Our Maintenance Programs and Modernization Services are backed by a extensive expertise for all types of industrial door and docking systems, independent of brand. At your disposal is a team of dedicated expert technicians, proven through decades of maintenance, service and satisfied customers.

Preventive Maintenance Programs

Minimizing lost time, lost energy and unexpected hassle is our team's constant objective. Our service organization can support you 24/7 in maintaining all industrial door and docking systems, independent of brand. If you want to be one step ahead of break-downs, explore our portfolio of Pro-Active Care plans. Naturally, we also offer entrance upgrades to suit your specific wishes and business needs.

Pro-Active Care - Maintenance plans to fit your business

Regular maintenance can extend the lifetime of your equipment and help prevent unexpected problems. Our technician arrives on-site equipped with the knowledge and tools to service all automatic entrances, independent of brand.

- **Pro-Active Bronze**

The base on which all Pro-Active Plans are built provides the security of knowing that your equipment is regularly inspected and certified for safety, as well as performing optimally. It includes a number of planned on-site visits depending on your needs. Any unplanned service calls required during the term of the contract (including labor, travel and parts) are billed at special Pro-Active Care prices.

- **Pro-Active Silver**

This plan provides all the benefits of Pro-Active Bronze with the added advantage of labor and travel being included for service calls during regular business hours. The only additional charge would be for any parts that may be needed throughout the term of the contract.

- **Pro-Active Gold**

This plan provides the ultimate protection for your automatic entrance investment. It includes all the benefits of Pro-Active Silver, plus replacement of any parts required during an unplanned repair or planned maintenance visit. Pro-Active Gold is an excellent way to budget your automatic door expenses annually.

- **Pro-Active Tailor-Flex**

Our most flexible maintenance and service offering. The Pro-Active Care plan is designed by you, our customer. The plan allows you to balance your maintenance expenses against your real-world budget and presents the option to add or delete a number of maintenance elements to suit your budget goals, while meeting your overall performance and safety needs.

Modernization

Your entrances are a long-term investment, from which you always want the best. Products develop over time, so do regulations and your business. Let us help you increase energy savings and meet today's standards. We provide advice and modernization kits for outdated installations, ensuring your investment meet requirements and performs optimally for many more years to come.

Re-Active Service		Pro-Active Care				
		Pro-Active Bronze	Pro-Active Silver	Pro-Active Gold	Pro-Active Tailor Flex	
		○	○	○	●	Other customized requests such as Response Time, Performance InfoPack and Advanced User Training
		○	○	●	○	Replacement of worn parts according to preventive Consumable Exchange Program
		○	○	●	○	Replacement of spare parts on breakdowns
		○	●	●	○	Travel and labor for additional call-out visits
		●	●	●	●	Preventive maintenance visits 1-4 times per year
		●	●	●	●	Travel and labor for preventive maintenance visits
		●	●	●	●	Response time and priority on call-outs <24h
		●	●	●	●	Preventive planned maintenance that meets the most demanding standards in the market
	●	●	●	●	●	Safety and quality checks according to applicable regulations and norms. Documentation of test results provided
●	●	●	●	●	●	Documentation of equipment status, assessment and service provided, all generated on site
●	●	●	●	●	●	Highly trained professional technicians with extensive knowledge, state-of-the-art tools and the right spare parts*
●	●	●	●	●	●	Dedicated Professional Customer Care Hotline
Corrective	SafetyCheck	Pro-Active Bronze	Pro-Active Silver	Pro-Active Gold	Pro-Active Tailor Flex	

● = Included as standard
 ○ = Available at special prices
 * Well-stocked service vehicles with genuine and new spare parts

Index

Numerics

950 Docking DLA TD	9
950 Docking DLSA TD	9
950 Docking LA TD	9
950 Docking LSA TD	9

A

Application	6
ASSA ABLOY DE6090DI Dock-IN	
Autodock	12
ASSA ABLOY DE6090DL Dock light	
Heavy Duty LED	12
ASSA ABLOY DE6090E Eye	11
ASSA ABLOY DE6090TLS Traffic light	
system	12
ASSA ABLOY DE6090WC Wheel chock	
12	
Available Options	13
Axle load	14

B

B - frame	21
Buffers	10
Building and space requirements ...	19

C

CEN Performance	18
Colors	8
Control units	17
Copyright and Disclaimer Notice	2

D

Description	6
Dimensions	16, 17
Dock management	10
Dock-IN Red	12
Dock-IN White	12
Dock-IN White & Red	13
Docking control systems	9
Dynamic load	14

E

EBF	11
EBH	11
Electrical preparations	19
EPDM seal	7
Equipment	10
Example	14

F

Facility management	10
Features	3
Frames - connection to building	8
Free space under lip	15
Functions	17

G

General	6
---------------	---

H

Hot galvanising	8
-----------------------	---

L

Lip material	7
Lip shapes	7
Load capacity according to EN 1398	14

M

Mode of operation	6
Monitoring systems	10

N

Nominal width	14
---------------------	----

O

Options	6
Overview	6

P

Paint classes	8
Painting	8
Parking guides	12
Performance	3
Pit preparations	20
Platform	7
Platform tear-plate thickness	7
Platform thickness	16

R

Rated load	14
RB	10
RB with steel construction	11
RB with steel construction and steel	
front plate	11
RB with steel front and top plate ...	11
RB with steel front plate	10
RS	10

S

Safety according to the European	
Standard EN 1398	18
Saving energy	10
Security enhancement	10
Select the leveler length	14
Select the load capacity	14
Selection guide	14
Service	22
Slip protection / noise reduction	7
Specifications	16
Standard	6
Standard paint class	8
Standard telescopic lip	7
Steel lip	15
Steel spring buffer 600	11
Steel spring buffer 800	11
Steel telescopic lip	7
Surface	8

T

T - frame	20
T - leveler frame for embedding in	
concrete	8
Tapered telescopic lip	7
Technical facts	3
Telescopic Lip	7
The calculation	14

W

W - frame	20
W - leveler frame for welding	8

ASSA ABLOY Entrance Systems is a leading supplier of entrance automation solutions for efficient flow of goods and people. With our globally recognized product brands Besam, Crawford, Albany and Megadoor, we offer products and services dedicated to satisfying end-user needs for safe, secure, convenient and sustainable operations.
ASSA ABLOY Entrance Systems is a division within ASSA ABLOY.

ASSA ABLOY

assaabloyentrance.com

Q3.0 - 2016



ASSA ABLOY Entrance Systems

assaabloyentrance.com