

Product datasheet

Vertical lifting fabric door

Crawford VL3110

ASSA ABLOY

ASSA ABLOY Entrance Systems

The global leader in
door opening solutions



Copyright and Disclaimer Notice

Although the contents of this publication have been compiled with the greatest possible care, ASSA ABLOY Entrance Systems cannot accept liability for any damage that might arise from errors or omissions in this publication. We also reserve the right to make appropriate technical modifications/replacements without prior notice.

No rights can be derived from the contents of this document.

Color guides: Color differences may occur due to different printing and publication methods.

ASSA ABLOY, Besam, Crawford, Megadoor and Albany, as words and logos, are examples of trademarks owned by ASSA ABLOY Entrance Systems or companies within the ASSA ABLOY Group.

Copyright © ASSA ABLOY Entrance Systems AB 2006-2015.

No part of this publication may be copied or published by means of scanning, printing, photocopying, microfilm or any other process whatsoever without prior permission in writing by ASSA ABLOY Entrance Systems.

All rights reserved.

Technical facts

Features

Max size: (W / H)*	8000 x 12000 mm
Door leaf thickness:	100 mm
Fabric types:	Standard: Polyester (coating: plasticised PVC) Options: Arctic, sound reduction, heat resistant, security
Color:	9 standard colours
Guide rails material:	Aluminium
Windows:	Vision panels (800 x 800 mm standard)
Seals:	Bottom, side and top seal
Operation:	Standard: Electrical operator Optional: Automated operation, Access control, Safety functions

* Other sizes may be available on request

Performance

Operating speed:	Normal opening speed: 0.2-0.3 m/sec Increased opening speed: 0.4-0.6 m/sec
Wind load resistance*: (differential pressure)	0.45-1.6 kPa, depending on size Class 2-5, EN 12424
Wind speed, door in motion:	< 20 m/s
Sound reduction (standard):	15 dB Rw (ISO 717)
Water resistance:	0.11 kPa (for a closed door) Class 3, EN 12425
Air permeability:	12 m ³ /(m ² h) Class 2, EN 12426
Operating environment temperature range:	-35 °C to +70 °C

* Higher wind loads on request.

Contents

Copyright and Disclaimer Notice	2
Technical facts	3
Contents	4
1. Description	6
1.1 General	6
1.1.1 Standard	6
1.1.2 Options	6
1.2 Door leaf	7
1.2.1 Construction	7
1.2.2 Intermediate section	7
1.2.3 Bottom section	7
1.2.4 Safety arresters	7
1.2.5 Material	8
1.2.6 Colors	8
1.2.7 Options	8
1.3 Guide rails	9
1.3.1 Jamb	9
1.3.2 Extension jamb	10
1.3.3 Wind deflectors	10
1.4 Header box	10
1.4.1 Header box options	10
1.4.2 Self-supporting header box	11
1.5 Operating system	11
1.5.1 Electrical operation	11
1.5.2 Belt system	11
1.5.3 Gear motor	11
1.5.4 Control unit	12
1.5.5 Safety edge	12
1.5.6 Access and automation	12
2. Specifications	15
2.1 Clear width and clear height	15
2.2 Performance	15
2.3 Environmental tolerance	15
2.4 Surface treatment	15
2.5 Door leaf	16
2.5.1 Fabric data	16
2.6 Operating system	20
2.6.1 General specifications	20
3. CEN Performance	21
3.1 Lifetime expectation	21
3.2 Resistance to wind load	21
3.3 Resistance to water penetration	21
3.4 Air permeability	21
3.5 Thermal transmittance	22
3.6 Acoustic insulation	22
3.7 Operating forces and safe openings	22

4.	Building and space requirements	23
4.1	Building preparations	23
4.1.1	Installation of the header box.....	23
4.1.2	Mounting surfaces for guide rails	26
4.1.3	Installation of the guide rails	27
4.2	Space requirements	29
4.2.1	Space requirements for operation.....	29
4.2.2	Space requirements for control unit.....	30
4.2.3	Space requirements for maintenance	30
4.2.4	Space requirements - Installation against wall	31
4.2.5	Space requirements - Installation against wall between columns.....	32
4.2.6	Space requirements - Installation with self-supporting header box	33
4.2.7	Space requirements - Installation in door opening	34
5.	Service	35
	Index	38

1. Description

1.1 General

The Crawford VL3110 vertical lifting fabric door is especially designed for extreme industrial environments where doors are exposed to moisture, dust and very high or low temperatures, or where the door opening is large.

The unique design and structure offers durability, tightness, energy efficiency, operational reliability and minimum maintenance. Every door is individually designed to meet application requirements, for example wind load.

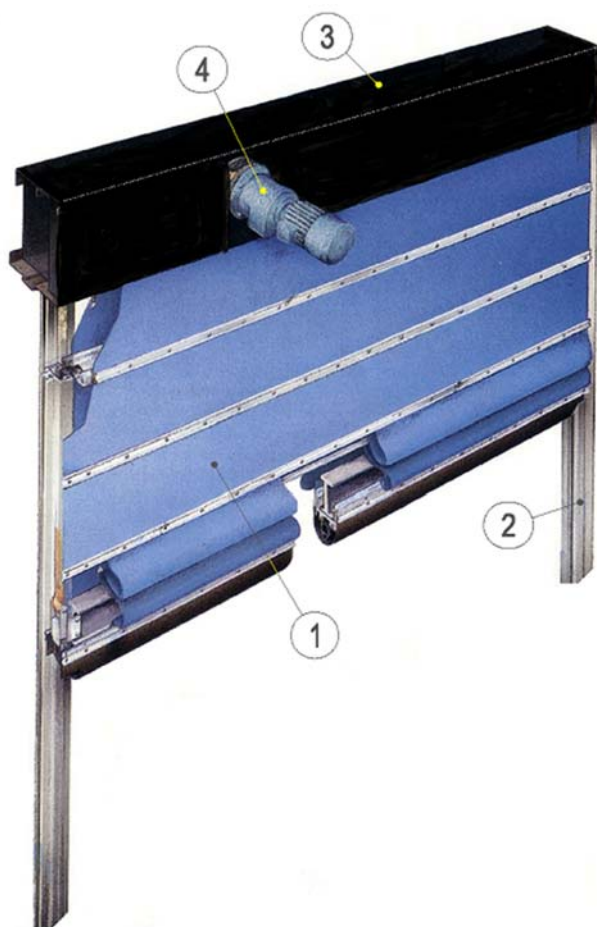

The Crawford VL3110 vertical lifting fabric door has 4 primary parts:

- 1) Door leaf
- 2) Guide rails
- 3) Header box
- 4) Operating system

1.1.1 Standard

The Crawford VL3110 vertical lifting fabric door is supplied with the following specifications as standard:

Door leaf:	Polyester, 1100 dtex with plasticised PVC coating
Safety:	Safety arresters Optical safety edge
Operation:	Operator + control unit
Colors:	Choice of 9 standard colours

1.1.2 Options

ASSA ABLOY Entrance Systems provides a wide range of options and accessories to customise the Crawford VL3110 vertical lifting fabric door to any customers needs. For example:

Door leaf:	Arctic, heat resistant, sound reduction and security fabrics Vision panels
Guide rails:	Jambes for protection and insulation Heating cables
Header box:	Protective cladding
Colors:	Optional colors on request
Operation:	Automation

1.2 Door leaf

1.2.1 Construction

The door leaf is made of two layers of very strong vinyl-coated polyester fabric, separated by aluminium intermediate sections. The aluminium top section is bolted to the header box, the steel and aluminium bottom section is connected to the lifting belt via the safety arresters.

The fabric is attached to both sides of the intermediate sections, top section and bottom section with self-tapping screws through aluminium clamp strips, providing maximum tightness.

Wind load is transferred to the vertical guide rails by the horizontal aluminium sections of the door leaf.

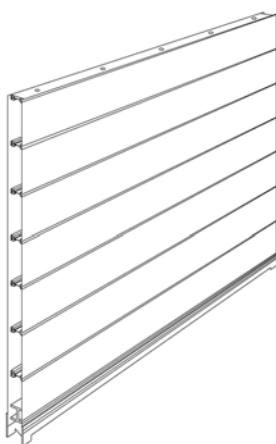

1.2.2 Intermediate section

The intermediate sections give strength to the door leaf and create a buffer between the inside and outside fabric walls. Self-lubricating slide blocks at each end of the intermediate sections run in the guide rails when the door opens and closes.

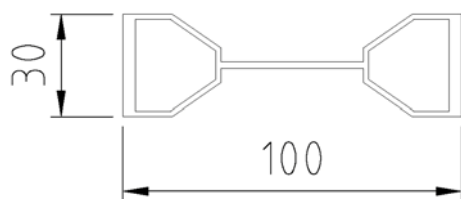

1.2.3 Bottom section

The bottom section, made of steel and aluminium, is connected to the lifting belt via the safety arresters. The bottom section contains a safety edge and a rubber seal on the bottom edge that creates a seal between the door and the floor.

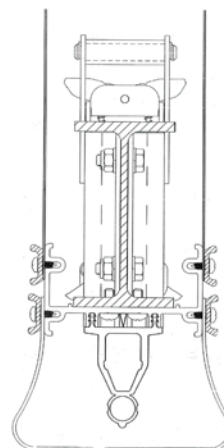

1.2.4 Safety arresters

The safety arresters are connected to each end of the bottom section. The lifting belt is connected to the safety arresters.

The safety arresters have four hooks. The two upper hooks operate as a wind lock when the door is closed. The two lower hooks are the safety hooks and grip the guide rails to stop the door if the lifting belt becomes slack or, in an unlikely event, would break.



1.2.5 Material

Standard Fabric

The standard door-leaf fabric is a single sheet of heavy-duty vinyl-coated polyester. The fabric is resistant to mechanical abrasion and sparks generated from mechanical processes such as welding.

The standard fabric is available in 9 standard colours, however other colors are available on request.

Arctic Fabric

The arctic fabric replaces the standard fabric in environments where the temperature can be as low as -54°C.

Sound-reduction Fabric

The sound-reduction fabric is for use in environments where the transmission of sound through the door must be reduced. It is installed on both sides of the door leaf behind the standard fabric.

Heat-resistant Fabric

The heat-resistant fabric replaces the standard fabric on the inside of the door leaf when there is a requirement to contain heat and/or chemical hazards. It is available with three different coatings dependant on the environment where it is going to be used.

Security Fabric

The security fabric is for use in environments where security is important. It is similar to the standard fabric with the addition of galvanized steel wires inside the fabric. It is installed on both sides of the door leaf behind the standard fabric to a height of about two meters.

Vision Panels

Vision panels (windows) are available for the standard and arctic fabrics to improve light admission and visibility through the door leaf. The vision panels are available in four different sizes.

1.2.6 Colors

The RAL-colors are as close as possible to the official RAL HR collection.

1.2.6.1 Standard colors

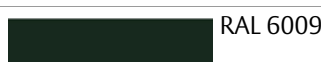

Translucent white

1.2.6.2 Optional colors

Other colors are available on request.

1.2.7 Options

Painted clamp strips

Painted clamp strips are available in the same standard colors as the fabric.

The benefits of the clamp strip covers are:

- Improve the appearance of the door leaf
- Protect the door leaf from discoloration in certain environments.

1.3 Guide rails

The vertical guide rails are made from extruded aluminium. The lubrication-free slide blocks at each end of the door leaf sections travel through these guide rails.

The guide rails have weather sealing on the inside and outside faces. There is also a space inside the guide rails for the lifting belt of the drive unit and safety arresters.

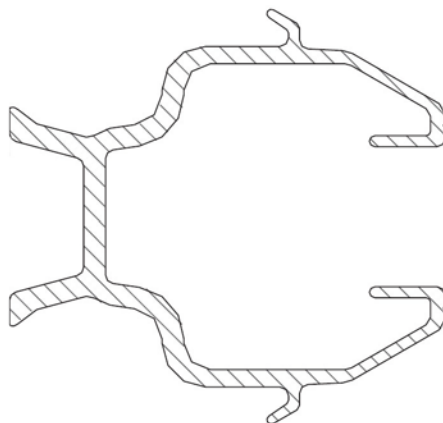

1.3.1 Jambs

If posts for installing the guide rails are not available, stable jambs can be provided. These jambs can be installed, against a concrete or steel wall structure, in the same way as the guide rails. It is possible to insulate the jambs, but material for the purpose is not included in the delivery. The jambs are made of steel painted black.

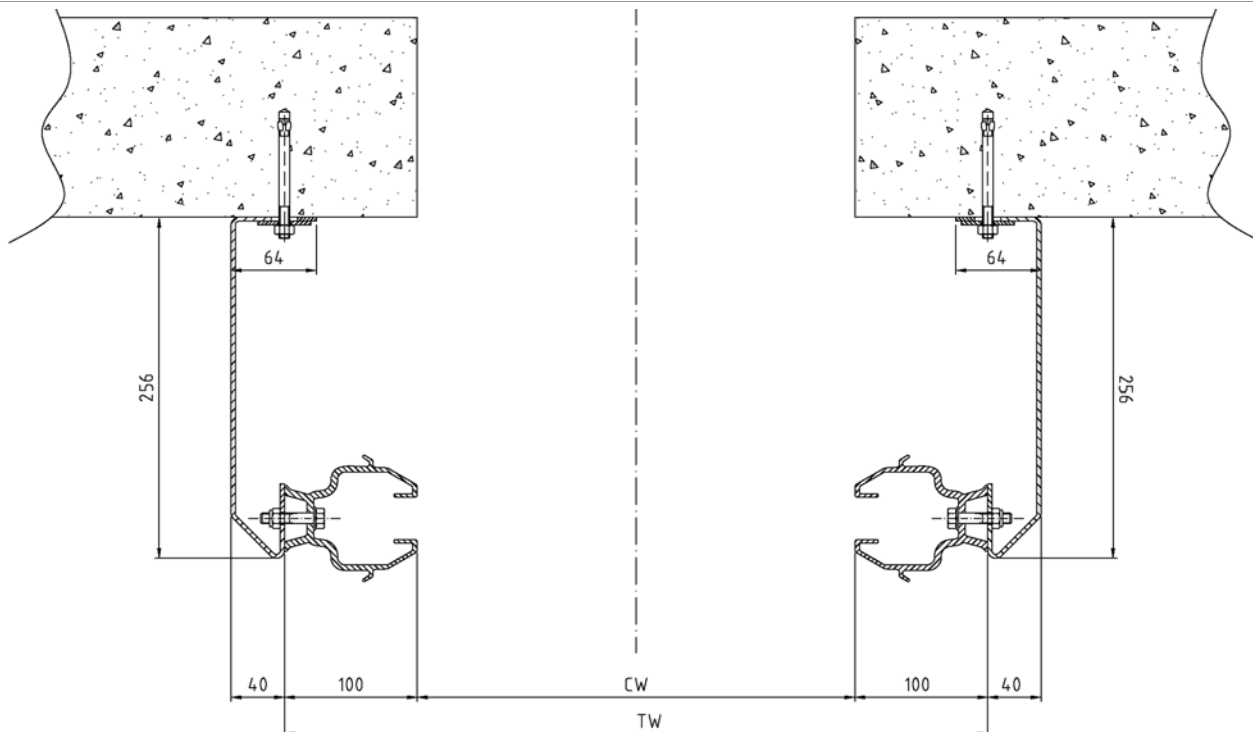

1.3.2 Extension jamb

An exterior jamb is suitable for the Crawford VL3110 vertical lifting fabric door, making it possible to connect to an existing steel construction and still obtain a shielded location for the guide rails.

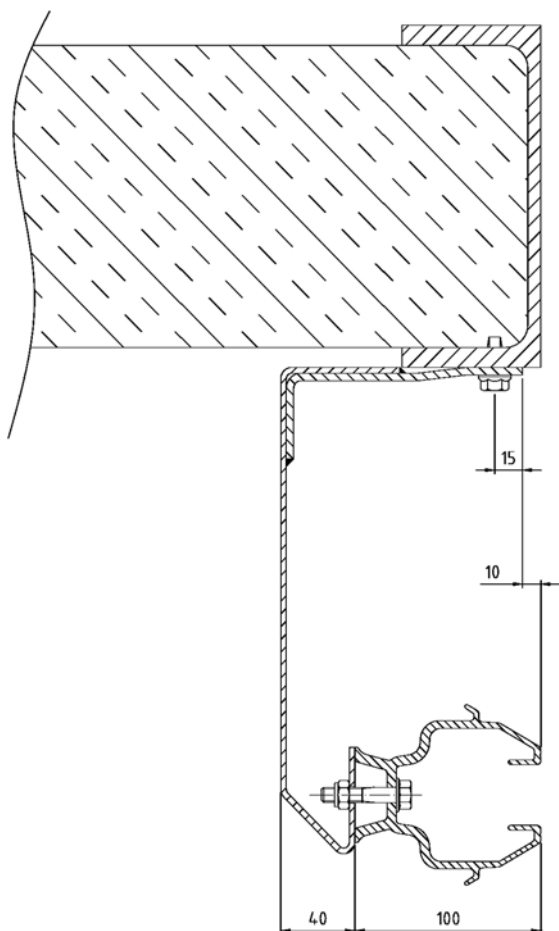

1.3.3 Wind deflectors

Used with jambs to avoid strong side winds, pressing sand or snow inside the door leaf.

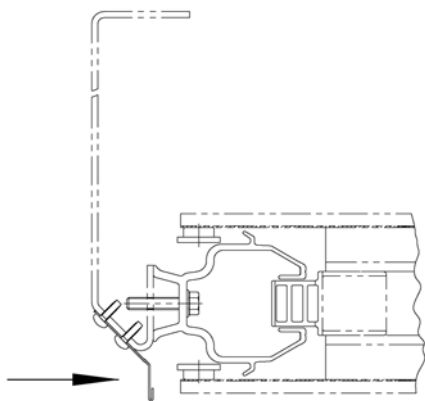

1.4 Header box

The header box contains the gear motor, the belt drum, lifting belts, pulleys and limit switch boxes. It can be installed with the gear motor on the inside or the outside of the building. As standard, the motor side of the header box is enclosed by powder-coated sheet steel covers. Cover plates allow access to components that need maintenance.

1.4.1 Header box options

1.4.1.1 Non-motor side covered

If the header box is positioned in the door opening with the gear motor facing inwards, the non-motor side should be fitted with a cover. An inspection can still be done from the motor side, in this case from inside the building. The header box can be insulated as an option.

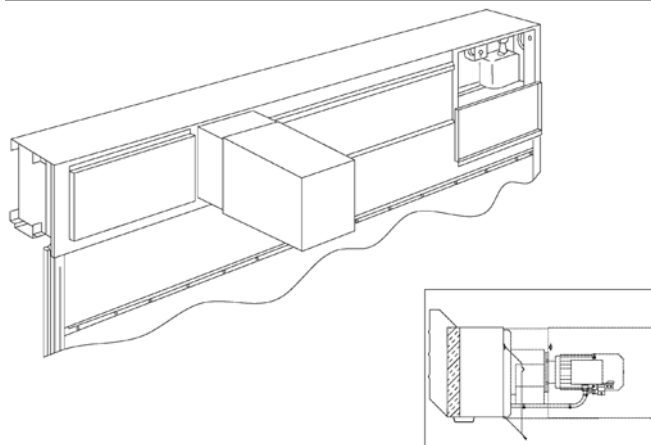

1.4.1.2 Protective casing for motor

In corrosive or dirty environments, the motor should be fully protected. The protective casing is made of powder-coated sheet steel. The casing has a hatch to facilitate easy access to the motor for emergency operation. The casing is detachable. Existing doors can also be equipped with a protective casing.

1.4.1.3 Stainless steel cladding and motor casing

In corrosive environments, the header box, including the mechanical unit, can be enclosed in stainless steel casing.

1.4.1.4 Limit switch boxes

The limit switch boxes contain inductive proximity switches with high ingress protection level (IP67) and temperature tolerance.

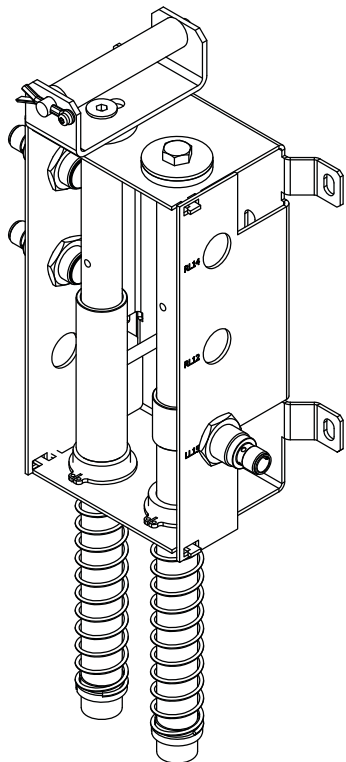

1.4.2 Self-supporting header box

If there is no suitable installation surface above the door opening, a self-supporting header box can be installed. A supporting beam, installed on the bottom of the header box, transfers the weight of the header box and the door leaf via the jambs to the building.

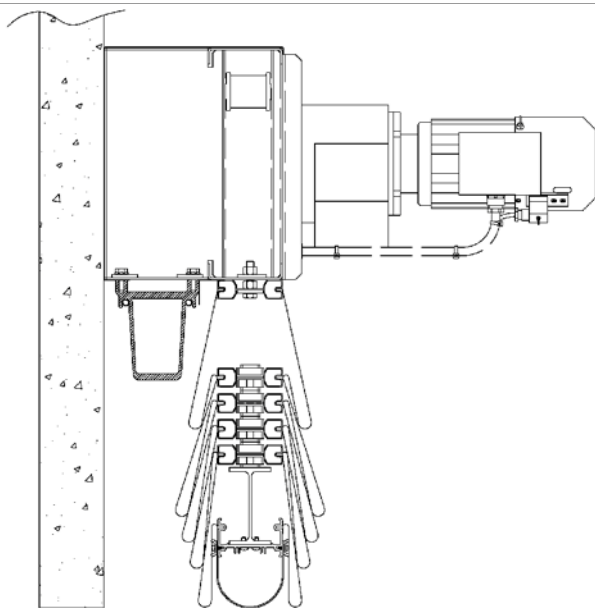

1.5 Operating system

1.5.1 Electrical operation

The Crawford VL3110 vertical lifting fabric door is always supplied with an electrical operating system, a control unit near the door and a gear motor in the header box.

The door is opened by an impulse from the UP-button or from an optional device, such as a radar or magnetic loop.

The door is closed by an impulse from the DOWN-button or by an optional device.

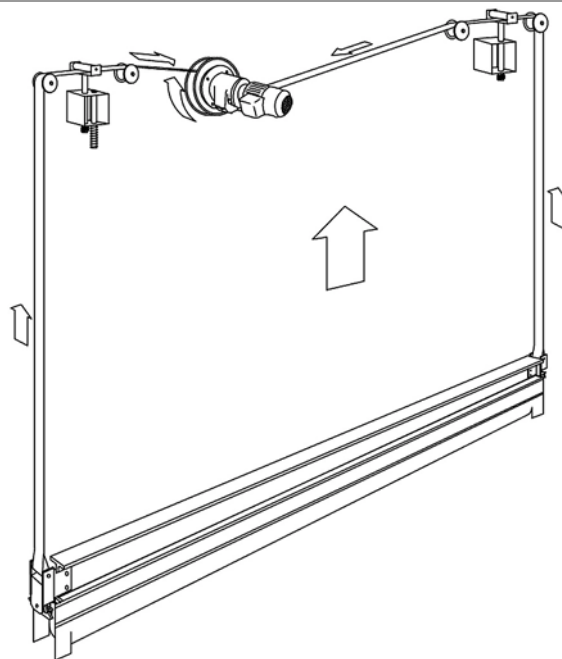

1.5.2 Belt system

The belt system consists of one lifting belt that can withstand corrosion, dust and dirt. This belt is connected to the safety arresters at both ends of the bottom section, through the guide rails, up to the belt drum. The belt drum is installed on the output shaft of a braked reduction-gear motor by a keyed joint.

1.5.3 Gear motor

The gear motor is suited for the actual weight of the door leaf. The electric gear motor winds the belt onto a drum.

In the event of a power failure, the door can be manually operated by means of a hand crank connected to the motor.

1.5.4 Control unit

The door is supplied with a PLC-based control unit installed near the door. The control unit commands the gear motor via push buttons or via external activators, e.g. a mechanical loop or radar.

The UP and DOWN buttons are operated by impulse. The DOWN button can be set to hold-to-run. The gear motor can be disabled from the control unit for emergency hand-crank operation by switching off the mains.



1.5.4.1 PLC

The control unit contains a PLC for the setting of timers, automatic and safety functions. The PLC is programmed and configured before delivery. The menu* gives the following information:

- Number of days of operation and number of door openings from the start since the door was last serviced.
- Current settings
- Alarm codes

* Optional human machine interface display required.

1.5.4.2 Temperature control

An optional heating element can be installed in the control unit, to avoid moisture inside the unit at low and variable temperatures and in moist air

1.5.5 Safety edge

The Crawford VL3110 vertical lifting fabric door has a safety edge on the bottom of the door. If the door hits an obstacle, the door will stop and return to its original position. The safety edge is either optical or conductive.

In an optical safety edge an IR beam runs through an enclosed rubber tube. The steel profile in the bottom section ensures a straight line across the entire width of the door.

The optional conductive rubber safety edge has a pre-fitted resistor that is monitored through wires extruded through the length of the rubber. The wires are connected to two separated conductive rubber surfaces.

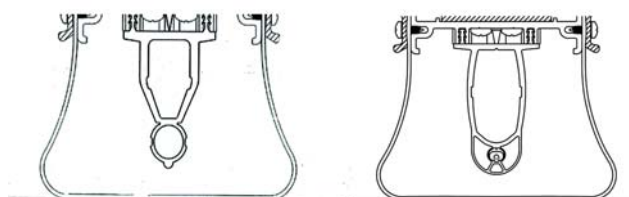

1.5.6 Access and automation

ASSA ABLOY Entrance Systems offers a wide range of functions that allow advanced opening and safety control.

1.5.6.1 Basic control functions

Hold-to-run control

If required, the door can be supplied without safety edge, with closing by hold-to-run control as only alternative.

Interlocking



Developed for climate control or safety; if door A is open, door B cannot be opened. If door B is open; door A cannot be opened.

Reduced opening

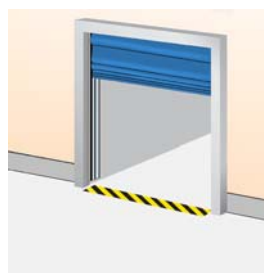

When it is unnecessary or undesirable to fully open a door, an additional timer can be used to open the door to a pre-programmed reduced opening position.

1.5.6.2 External control functions

Pull-rope switch



A pull rope switch next to the door opening can be operated from e.g. a forklift truck. Pulling the rope opens a closed door or closes an open door. Installed on the wall, with bracket.

External push button box

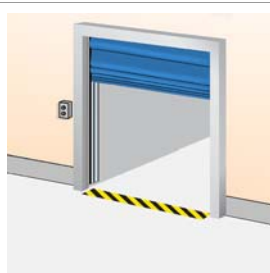

An extra control box is installed outside the building or inside close to the door if the main control unit needs to be installed away from the door opening. Installed on the inside or outside wall beside the door.

Remote control

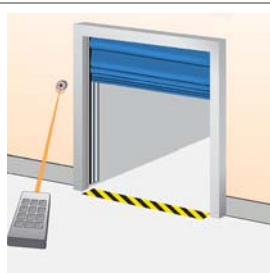

A hand-held radio transmitter allows door operation from a vehicle or any position within 50-100 meters from the receiver and aerial at the door. For closing, the door can be provided with a photocell beam. A receiver is installed either inside or next to the control unit.

1.5.6.3 Automatic control functions

The function of all sensors is individually configurable in the HMI display. Interlock/safety, automatic opening, automatic closing and alternating automatic opening and closing are selectable functions.

Magnetic loop



A sensor in the floor detects a metal object (usually forklift trucks, pallet trucks). This is an ideal solution for frequent vehicle traffic. Installed on the outside, inside or both sides of the door in the ground.

Radar

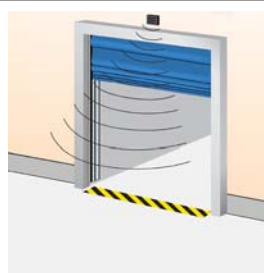

An infrared sensor above the door detects an object (person, vehicle) within a specified distance from the door. This is an ideal solution for frequent vehicle or personal traffic. Often combined with automatic closing. Installed on the inside or outside wall above the door.

Photocell

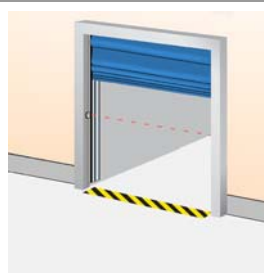

A set of photocells is installed on pillars, on each side of the door. When a person or vehicle passes between the photocells, the beam is interrupted.

Automatic closing

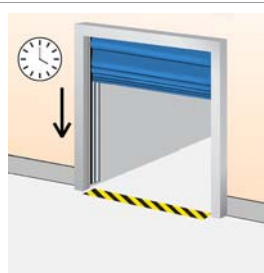

A programmable timer that closes the door after a specified time, counted from either the fully open position and/or from passing through the photocell beam. Selector switch in control unit.

Automatic opening and closing

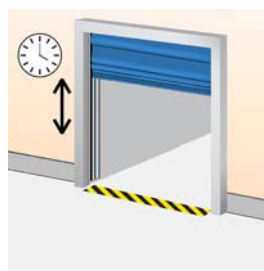

A programmable timer that closes the door after a specified time, counted from either the fully open position and/or from passing the photocell beam. A sensor, e.g. a magnetic loop or a radar, is used for automatic opening. Selector switch in control box and magnetic loop or radar.

1.5.6.4 Safety functions

Safety photocells 1-channel

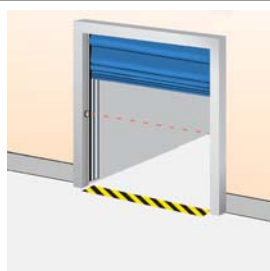

A set of a photocell transmitter with reflector or receiver is installed in the door opening. If the photocell beam is interrupted during closing, the door will stop and reverse to the fully open position.
Installed in the door opening.

Safety photocells 2-channel

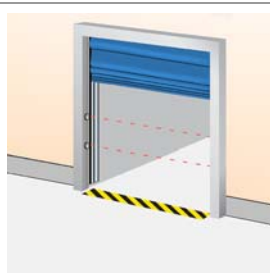

Two sets of photocell transmitters with reflectors and receivers are installed in the door opening. If one or both photocell beams are interrupted during closing, the door will stop and reverse to the fully open position.
Installed in the door opening.

Warning lights - Red

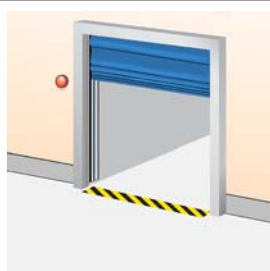

One or two red warning lights indicating that the door is moving or closed; continuous light when the door is closed, flashing light when the door is moving or not fully open.
Installed on the inside and/or outside wall beside the door.

Warning lights - Green

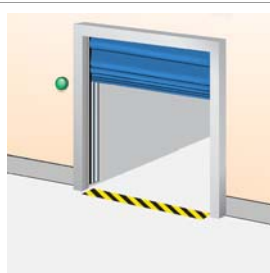

One or two green warning lights indicating the open position of the door by continuous light signal.
Installed on the inside and/or outside wall beside the door.

Warning lights - Orange flashing lights



Flashing light during door movement.
Optional; Flashing lights during an adjustable time period before automatic closing. Automatic closing required.
Installed on the inside and-or outside wall beside the door.

Acoustic signal

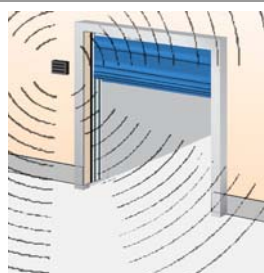

An acoustic signal is given, starting just before the door begins to open or close and continues until the door is fully opened or closed.
Installed on the wall beside the door.

Emergency power switch



An external power switch can be enabled, as a backup system, in case of a power failure.
Supplied with steel casing and power inlet socket.

1.5.6.5 Additional functions

Increased opening speed

The door can be equipped with an optional motor that doubles the opening speed to 0.4 - 0.6 m/s.

2. Specifications

2.1 Clear width and clear height

The standard Crawford VL3110 vertical lifting fabric door is delivered in the following size range:

Standard door sizes*

	Clear width	Clear height
Min.:	1810 mm	
Max.:	8000 mm	12000 mm

* Other sizes may be available on request

2.2 Performance

Operating speed:	Normal opening speed: 0.2-0.3 m/sec Increased opening speed: 0.4-0.6 m/sec
Wind load resistance*: (differential pressure)	0.45-1.6 kPa, depending on size Class 2-5, EN 12424
Wind speed, door in motion:	< 20 m/s
Sound reduction (standard):	15 dB Rw (ISO 717)
Water resistance:	0.11 kPa (for a closed door) Class 3, EN 12425
Air permeability:	12 m ³ /(m ² h) Class 2, EN 12426
Operating environment temperature range:	-35 °C to +70 °C

* Higher wind loads on request.

2.3 Environmental tolerance

Heat and cold resistance	-35°C to +70°C
Atmospheric humidity	below dew point
Presence of particles	< 1000 µg/m ³ air
Mechanical load, blasting	Not directly aimed.
Wind speed, in motion	< 20 m/s
Acidity	Condensate at 5<pH<9
Explosive fumes or dust	No occurrence.

*In the normal version, the door is suited for operation in environments within the limits stated above. If the requirements exceed these limits (e.g. wind load), the door can often be modified on request.

2.4 Surface treatment

Steel components	For corrosion, category 3 according to ISO 12944.2. Higher class on request.
Other parts	Aluminium, plastic, stainless steel, zinc electroplated steel (~ 10µ). Fixing elements are zinc electroplated (~ 10 µ).
	Door leaf screws are corrosion protected with Geomet.

2.5 Door leaf

2.5.1 Fabric data

2.5.1.1 Standard fabric

Application	Standard
Use	Standard
Coating	Plasticized PVC
Fabric	Polyester, 1100 dtex
Weight	700 g/m ²
Heat- and cold resistance	-35°C to +70°C. DIN EN 1876-2 1998-01. (-30°C to + 70°C for the Translucent white fabric)
Tensile strength	Warp : 2500N/5 cm acc. DIN 53354, EN ISO 1421 Weft : 2000N/5 cm acc. DIN 53354, EN ISO 1421
Tear resistance	Warp : 400N acc. DIN 53363 Weft : 300N acc. DIN 53363
Resistance to light	7 - 8 (on a scale 0-8). ISO 105-B02 1998
UV-stabilized	Yes
Fire classification	M2 (NF P 92 507 2004), B - s2,d0 (EN 13501-1 2007)
Mildew resistant	Yes
Rot resistant	Yes
Radar reflection	0.3 dB, - 0.1%
Lacquered	Yes
Standard colors	<ul style="list-style-type: none"> • Beige NCS 2010Y-40R RAL 1001 • Red NCS 2070-R RAL 3001 • Blue NCS S3560-R80B RAL 5005 • Green NCS 8010-G10Y RAL 6009 • Grey NCS 3500 RAL 7004 • Anthracite grey NCS 8005-B20G RAL 7016 • White NCS 0500 RAL 9016 • White aluminium RAL 9006 • Translucent white
Logotype	Optional
Vision panels	Optional

2.5.1.2 Arctic fabric

Application	Environmental temperatures down to -54°C			
Use	Replaces standard fabric			
Coating	Plasticized PVC			
Fabric	Polyester, 1100 dtex			
Weight	700 g/m ²			
Heat- and cold resistance	-54°C to +70°C. DIN EN 1876-2 1998-01			
Tensile strength	Warp : 2500N/5 cm acc. DIN 53354, EN ISO 1421 Weft : 2000N/5 cm acc. DIN 53354, EN ISO 1421			
Tear resistance	Warp : 400N acc DIN 53363 Weft : 300N acc. DIN 53363			
Resistance to light	7 - 8 (on a scale 0-8). ISO 105-B02			
UV-stabilized	Yes			
Fire classification	M2 (NF P 92 507 2004), B - s2,d0 (EN 13501-1 2007)			
Mildew resistant	Yes			
Rot resistant	Yes			
Radar reflection	0.3 dB, - 0.1%			
Lacquered	Yes			
Standard colors	•	Beige	NCS 2010Y-40R	RAL 1001
	•	Red	NCS 2070-R	RAL 3001
	•	Blue	NCS S3560-R80B	RAL 5005
	•	Green	NCS 8010-G10Y	RAL 6009
	•	Grey	NCS 3500	RAL 7004
	•	Anthracite grey	NCS 8005-B20G	RAL 7016
	•	White	NCS 0500	RAL 9016
	•	White aluminium		RAL 9006
Logotype	Optional			

Note! Not in combination with:

- Vision panels
- Sound reduction fabric
- Heat resistant fabric
- Security fabric

2.5.1.3 Sound reduction fabric

Application	Sound reduction
Use	On both sides of the door behind the standard fabric
Coating	Plasticized PVC
Fabric	Polyester, 1100 dtex
Weight	1850 g/m ²
Sound reduction (incl. standard fabric)	Index Rw23dB*, tested by SP Swedish National Testing and research Institute
Heat- and cold resistance	-30°C to +70°C, acc. SFS-EN 1876-1
Tensile strength	Warp: 3000N/5 cm acc. DIN 53354 Weft: 2900N/5 cm acc. DIN 53354
Tear resistance	Warp: 380N acc. DIN 53356 Weft: 300N acc. DIN 53356
Fire classification	Acc. SIS 650082, DIN 4102-B1
Comments	Space for fabric folding must be increased by 100 mm on each side of the door, to avoid fabric wear.

Note! Must always be quoted by ASSA ABLOY Entrance Systems.

* Weighted apparent sound reduction index acc. ISO 717-1. For more information, ask for SP-report P103341, dated 15 June 2001 'Determination of sound insulation of an industrial door according to SS-EN ISO-140-3:95'.

2.5.1.4 Heat resistant fabric - Silicone rubber coating

Application	<ul style="list-style-type: none"> Hot air environment Coating highly resistant to chemicals Good soil and oil repellent properties.
Use	Replacing standard fabric
Coating	Silicon rubber on both sides
Fabric	Woven glass fibre EC9-136 acc. to DIN53830-3
Weight	560 g/m ²
Temperature resistance	+280°C
Tensile strength warp/weft	800 / 600 N / 5 cm acc. to ISO 13934-1
Fire classification	M1 acc. to NF P92-507 ISO 5660-1 IMO Res. A.653 (16) IMO Res. MSC 41 (64) IMO FTP Code, Annex 2, section 2.2
Comments	<ul style="list-style-type: none"> Never combine standard and heat resistant fabric (for example upper part of the door with standard and lower part of the door with heat resistant fabric). Protect the bottom sealing with the fabric as well. When the door is installed against a wall on the cool side, the folding space on the hot side must be increased by at least 100 mm to avoid fabric wear. The motor should be placed on the cool side. A heat radiation shield below the motor may be necessary. All cables must be protected. The clear height should be as large as possible.

Note! Must always be quoted by ASSA ABLOY Entrance Systems.

2.5.1.5 Heat resistant fabric - Aluminium coating

Application	Hot air and high radiation temperatures inside (e.g. foundries). Good heat reflection properties.
Use	On the inside of the door (never on the outside) replacing standard fabric.
Coating	Aluminium pigments on polyurethane adhesive on one side of the fabric.
Fabric	E-glass EC9-136 (cross twill)
Weight	490 g/m ²
Heat- and cold resistance	From contact coating +200°C (not continuously)
Tensile strength	Warp : 800N/cm acc. DIN 53857 T1 Weft : 500N/cm acc. DIN 53857 T1
Fire classification	DIN 4102-1 A2
Comments	<ul style="list-style-type: none"> • Never combine standard and heat resistant fabric (for example upper part of the door with standard and lower part of the door with heat resistant fabric). • Protect the bottom sealing with the fabric as well. • When the door is installed against a wall on the cool side, the folding space on the hot side must be increased by at least 100 mm to avoid fabric wear. • The motor should be placed on the cool side. A heat radiation shield below the motor may be necessary. • All cables must be protected. • The clear height should be as large as possible.

Note! Must always be quoted by ASSA ABLOY Entrance Systems.

2.5.1.6 Heat resistant fabric - Aluminium polyurethane coating

Application	Fire resistant
Use	On the inside of the door (never on the outside) replacing standard fabric.
Coating	Two sides aluminium grey polyurethane
Thickness	0.8 mm
Fabric	Woven glass fibre, Atlas 1/8
Weight	690 g/m ²
Heat resistance	+450°C
Tensile strength	Warp : 1350N/cm acc. EN ISO 13934-1 Weft : 1260N/cm acc. EN ISO 13934-1
Fire classification	Incombustible according to M0 (French standard)
Comments	<ul style="list-style-type: none"> • Never combine standard and heat resistant fabric (for example upper part of the door with standard and lower part of the door with heat resistant fabric). • Protect the bottom sealing with the fabric as well. • When the door is installed against a wall on the cool side, the folding space on the hot side must be increased by at least 100 mm to avoid fabric wear. • The motor should be placed on the cool side. A heat radiation shield below the motor may be necessary. • All cables must be protected. <p>The clear height should be as large as possible.</p>

Note! Must always be quoted by ASSA ABLOY Entrance Systems.

2.5.1.7 Security fabric

Application	Protection against burglary
Use	On both sides of the door, behind the standard fabric. Up to approximately 2 meters from the floor
Fabric	PVC coated
Reinforcement	Multi-axial laid construction of galvanized steel wires
Weight	1350 g/m ²
Heat- and cold resistance	-30°C to +70°C
Fire classification	Not classified
Comments	Space for fabric folding must be increased by 100 mm on each side of the door, to avoid fabric wear.

Note! Must always be quoted by ASSA ABLOY Entrance Systems.

2.5.1.8 Vision panels

Application	Light admission and view through
Use	Only for standard fabric
Standard sizes	Width 800 or 1300 mm, height 800 or 1600 mm
Material	Elaston 064, 1 mm
Weight	1230 g/m ²
Hardness	77° shore acc. DIN 53505
Heat- and cold resistance	-30°C to +50°C
Tear resistance acc. DIN 53455	Along : 21 N/mm ² Crosswise : 20 N/mm ²

2.6 Operating system

2.6.1 General specifications

Control system	PLC-based
Protection class, control cabinet	IP65
Protection class, limit switches	IP67
Protection class, motor brake	IP55
Protection class, push buttons	IP65
Power supply	3/phase 400V 50Hz Other alternatives available on request
Control voltage	24 DC
Fusing	16 A
Free contacts (option)	6 for control of user functions
Heat and cold resistance	-35 °C to +70 °C
Motor ratings	0.47 - 2.8 kW

3. CEN Performance

The following tests have been carried out by the Swedish National Testing and Research Institute (SP) in Borås. For more detailed information and values, see ITT report: 0402-CDP-397307.

3.1 Lifetime expectation

- 100.000 door cycles

3.2 Resistance to wind load

EN12424

Test result	Class 2-5 (depending on door size).
-------------	-------------------------------------

Class	Pressure Pa (N/m ²)	Specification
0	-	No performance determined
1	300	
2	450	
3	700	
4	1000	
5	> 1000	Exceptional : Agreement between manufacturer and supplier

3.3 Resistance to water penetration

EN12425

Test result	Class 3 (110 Pa)
-------------	------------------

Class	Pressure Pa (N/m ²)	Specification
0	-	No performance determined
1	30	Water spray for 15 minutes
2	50	Water spray for 20 minutes
3	> 50	Exceptional : Agreement between manufacturer and supplier

3.4 Air permeability

EN12426

Test result	Class 2
-------------	---------

Class	Air permeability dp at a pressure of 50 Pa (m ³ /m ² /h)
0	-
1	24
2	12
3	6
4	3
5	1,5
6	Exceptional : Agreement between manufacturer and supplier

3.5 Thermal transmittance

EN12428

Thermal transmittance Depending on door size. Specific data available on request.

3.6 Acoustic insulation

ISO 717

Acoustic insulation 15 dB

3.7 Operating forces and safe openings

EN12453 & EN12604	Crushing force N	Crushing force N	Crushing force N
Opening gap mm	200 mm from lateral border right from outside	In the middle of the door opening	200 mm from lateral border left from outside
50 mm	passed	passed	passed
300 mm	passed	passed	passed

The crushing force is the force needed for the safety edge to be activated. The maximum force allowed, according to EN12453 safety in use of power operated doors is 400 N within a maximum period of time of 0.75s.

4. Building and space requirements

4.1 Building preparations

4.1.1 Installation of the header box

4.1.1.1 Basic installation

The Crawford VL3110 vertical lifting fabric door can be installed in three ways:

1. Internal wall mounting	2. Mounting in door opening	3. External wall mounting
Recommended if the size of the door opening permits it. The drive machinery and guide rails will then be fully protected.	Excellent alternative for an existing door opening. The risk of colliding with the guide rails should be negligible, or a collision shield should be used as protection.	Alternative when the inside environment is severe or when there is insufficient space above the door opening.

Side view header box

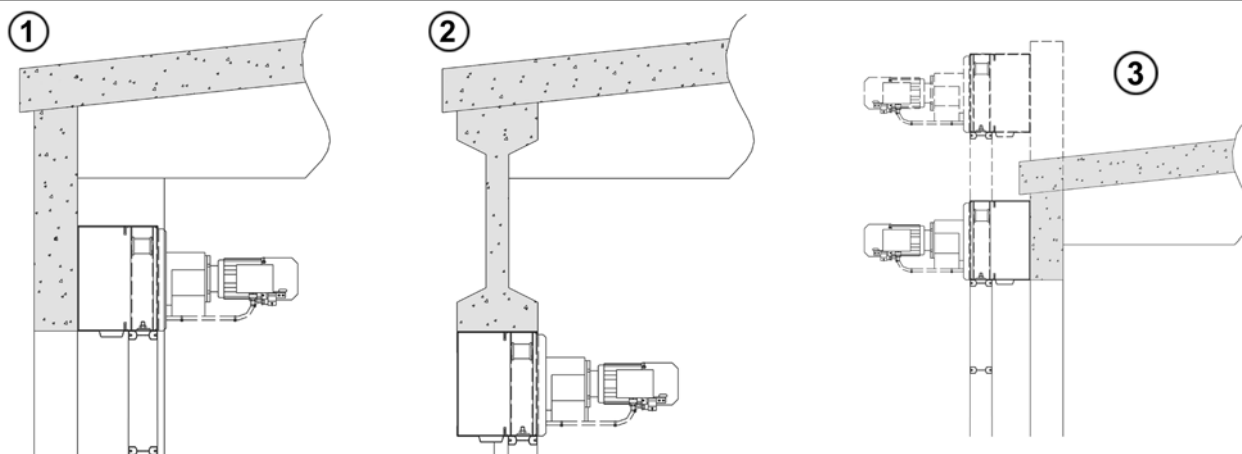

Top view guide rail and door leaf

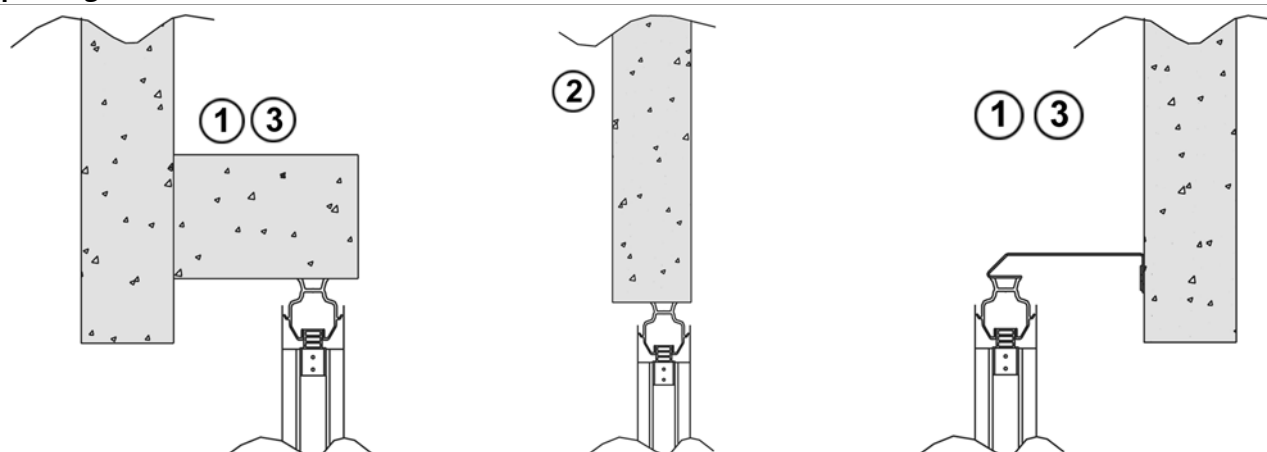

Installation surfaces for the header box must be flat, parallel and deviate maximum 5 mm from a horizontal line.
Min. thickness (t) of installation surface: steel 8 mm, concrete 100 mm. Min. width of each installation surface : 100 mm.

Installation surfaces – on wall

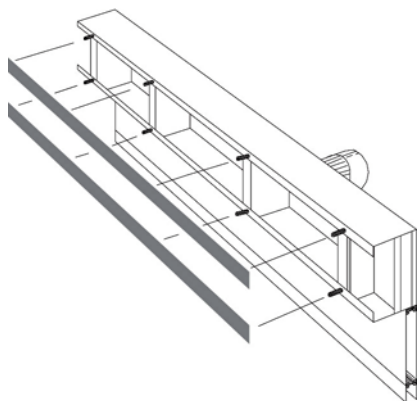

Installation surfaces – in door opening

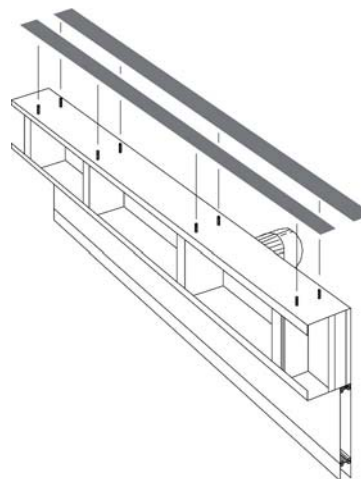

4.1.1.2 Load on the building

Door closed

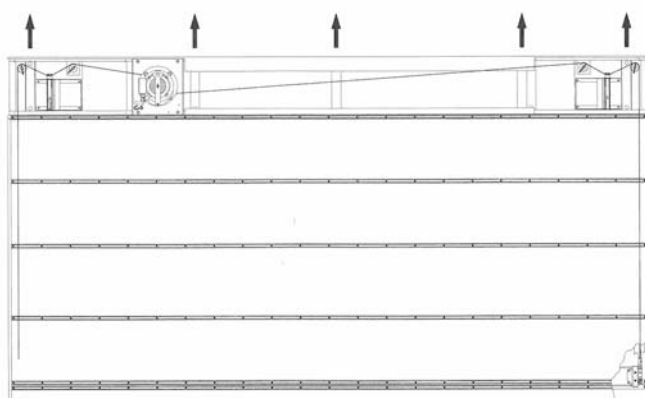

Door opened

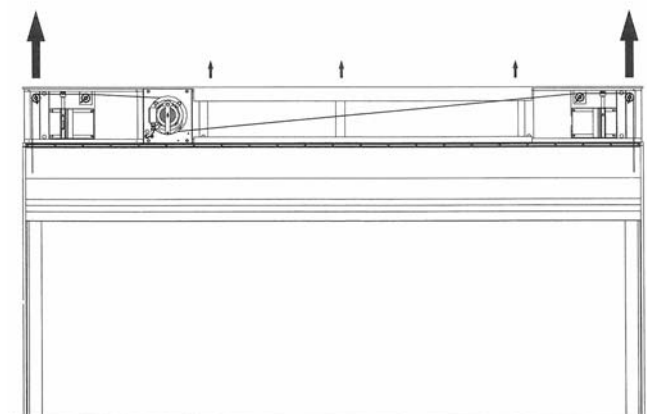

When the door is closed, the total weight is distributed on the fixing points. The distance between fixing points is about 1000 mm. The door leaf itself does not weigh more than 40 to 80 kg per meter width but, in view of the extra load which may result in the event of a collision, the total load of the building should be calculated at 1.5kN/m.

The load of the door leaf is successively transferred to the ends of the header box as the door is opened. In this situation it is mainly only the weight of the header box that rests on the other fixing points.

4.1.1.3 Self-supporting installation

Crawford can supply a self-supporting door if there is no suitable mounting surface over the door opening. A supporting beam, installed on the bottom of the header box, transfers the load of the header box via the jambs of the door to the building. The jambs support the beam and secure the guide rails.

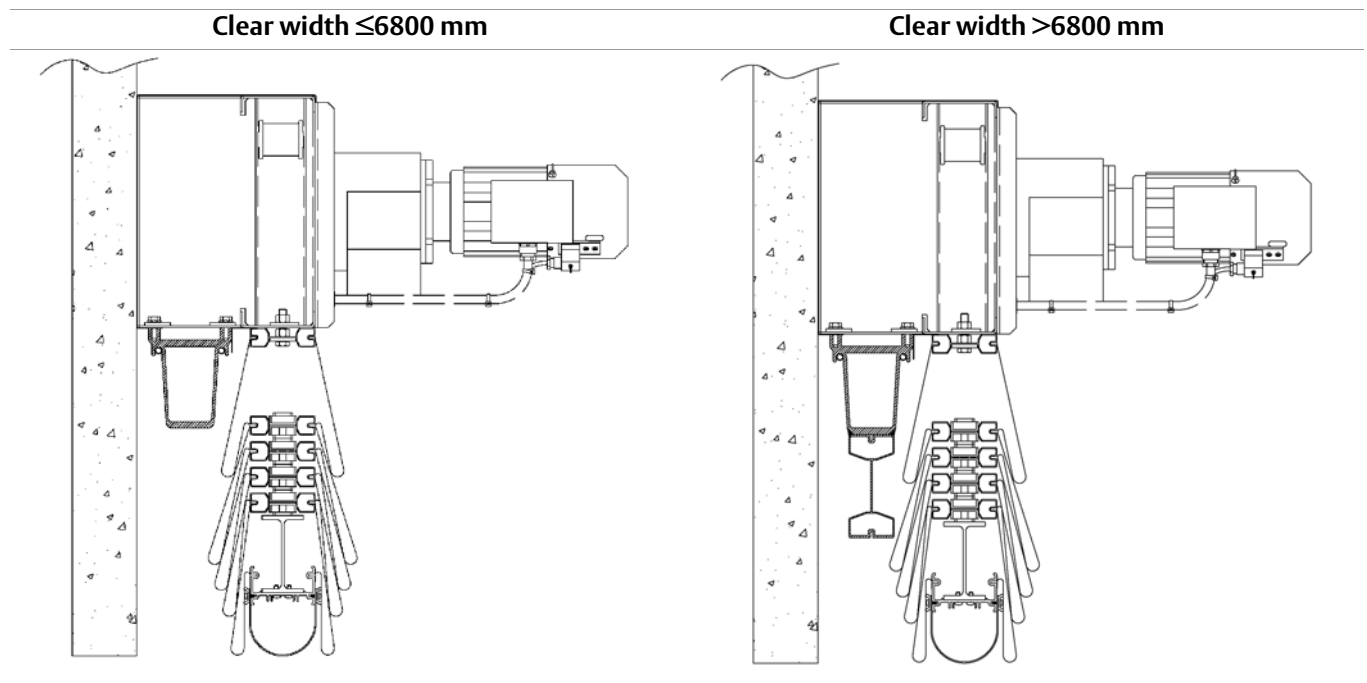

4.1.2 Mounting surfaces for guide rails

Suitable mounting surfaces must be available to facilitate the fitting of guide rails (see dark fields in the illustration). Mounting surfaces must be:

- Firm and smooth.
- Parallel and deviating not more than 5 mm from the vertical and not more than 2 mm/m in the inward or outward direction from the vertical.

Distance between fixing points should not exceed 1m.

Fastening:

Screw size: M8

Strength class: 8.8

Fixing surface, steel: $t \geq 6$

Fixing surface, concrete: $t \geq 90$

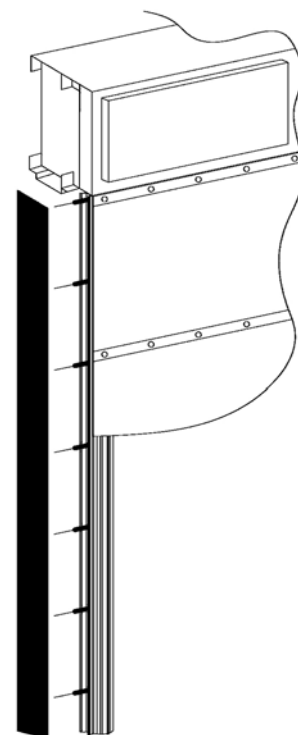

Steel:

Concrete:

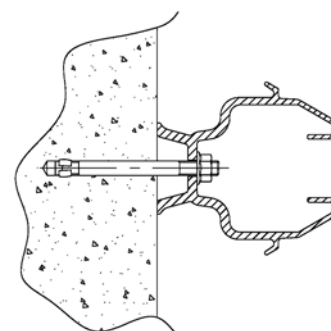
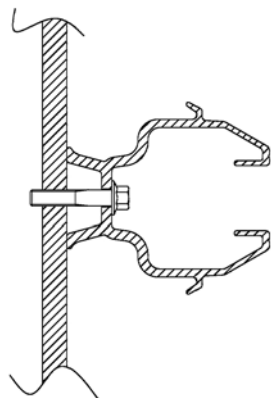

Secure the guide rails with self-threading screws

Drill holes in the concrete for expansion screws to secure the guide rails.

4.1.3 Installation of the guide rails

4.1.3.1 Basic installation

When installing on an existing surface, this surface must be made either from steel or concrete. The installation surfaces must be strong, smooth and parallel and deviate max. 5 mm from the vertical and 2 mm in the inward/outward direction from the vertical.

- Min. thickness of installation surface : steel 6 mm, concrete 90 mm.
- Min. width of installation surface : steel 50 mm, concrete 65 mm.

4.1.3.2 Installation with jambs

When the door is installed on a wall and posts for installation of the guide rails are not available, jambs of a stable design are provided. The jambs are installed in the same way as the guide rails, by screws or plugs with a spacing of about one meter. The jambs can be insulated (option), but this is not included in the standard delivery. The jambs are made of steel painted black.

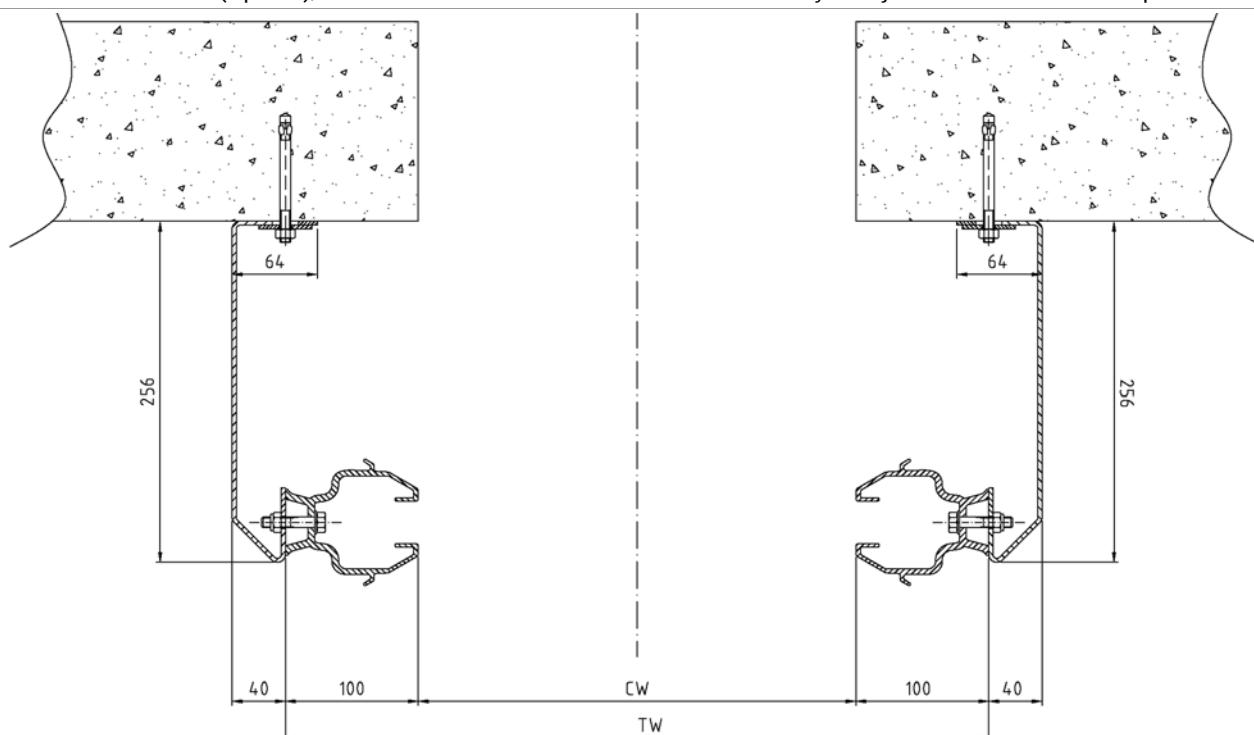

4.1.3.3 Extension jamb

An extension jamb is available for the VL3110 vertical lifting fabric door, making it possible to connect it to an existing steel construction and still obtain a shielded location for the guide rails.

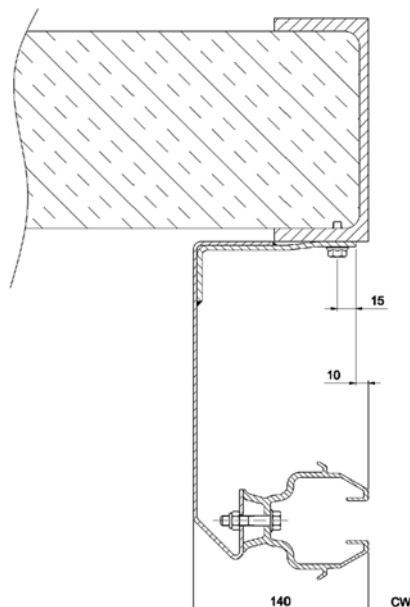

4.1.3.4 Installation of the control unit

The location of the control unit is best decided as follows :

Environment	Effect on control unit	Location of control unit
Normal environment	Negligible effect, IP65 protection is sufficient.	Close to the door
Harsh interior environment	When opened for maintenance, dust and moisture may enter	In a safe area
Sustainable temperature difference inside/outside	Condensation when door is opened	Away from the door. Push button unit close to the door
Strongly corrosive environment, no safe location possible	Optimum protection required	Stainless steel control unit

Also consider the space requirements of the control unit.

4.2 Space requirements

TH	Total height	Distance between floor and top of header box
CH	Clear height	Distance between floor and bottom of door leaf when door is fully opened
OH	Over height	Vertical space required above the clear height
TS	Total space requirement	Distance between outer side of jambs
TW	Total width	Distance between the left and right vertical installation surfaces.
CW	Clear width	Clearance distance between the left and the right guide rails.
MD	Motor depth	Depth of the header box + gear motor + extra space for hand crank
A		Door leaf thickness
B		Minimum free space required for fabric folding
C		Distance from rear side of header box to guide rail centre

4.2.1 Space requirements for operation

In contrast to other types of doors, the Crawford VL3110 vertical lifting fabric door requires only limited top and side space. The door leaf is compressed when opened. Even for a large door, the requirements are minimal.

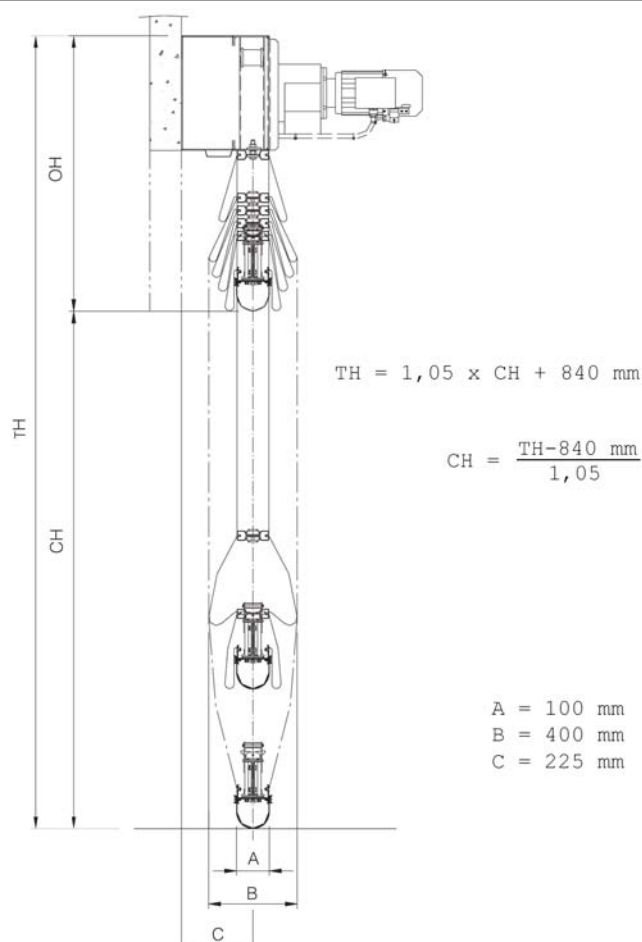

Space requirements for the self-supporting version are the same. For wind loads other than 0.7kPa, please contact your local ASSA ABLOY Entrance Systems representative.

4.2.2 Space requirements for control unit

The following dimensions (w x h x d) may be of assistance in deciding where to place the control cabinet, possible additional cables or an additional safety switch for the power supply :

Control unit size (steel)	500 x 600 x 250 mm
Control unit size (stainless steel)	600 x 600 x 250 mm

4.2.3 Space requirements for maintenance

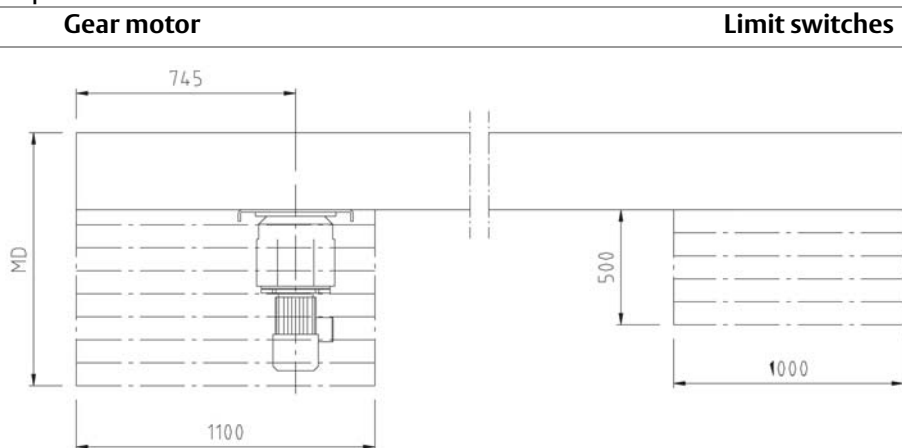

-
- MD = Motor depth. Depending on motor size.
 - MD = 750-1100 mm (+200 mm for hand crank).

Note: The motor is standard installed on the left side. Optional installation on the right side is possible

4.2.4 Space requirements - Installation against wall

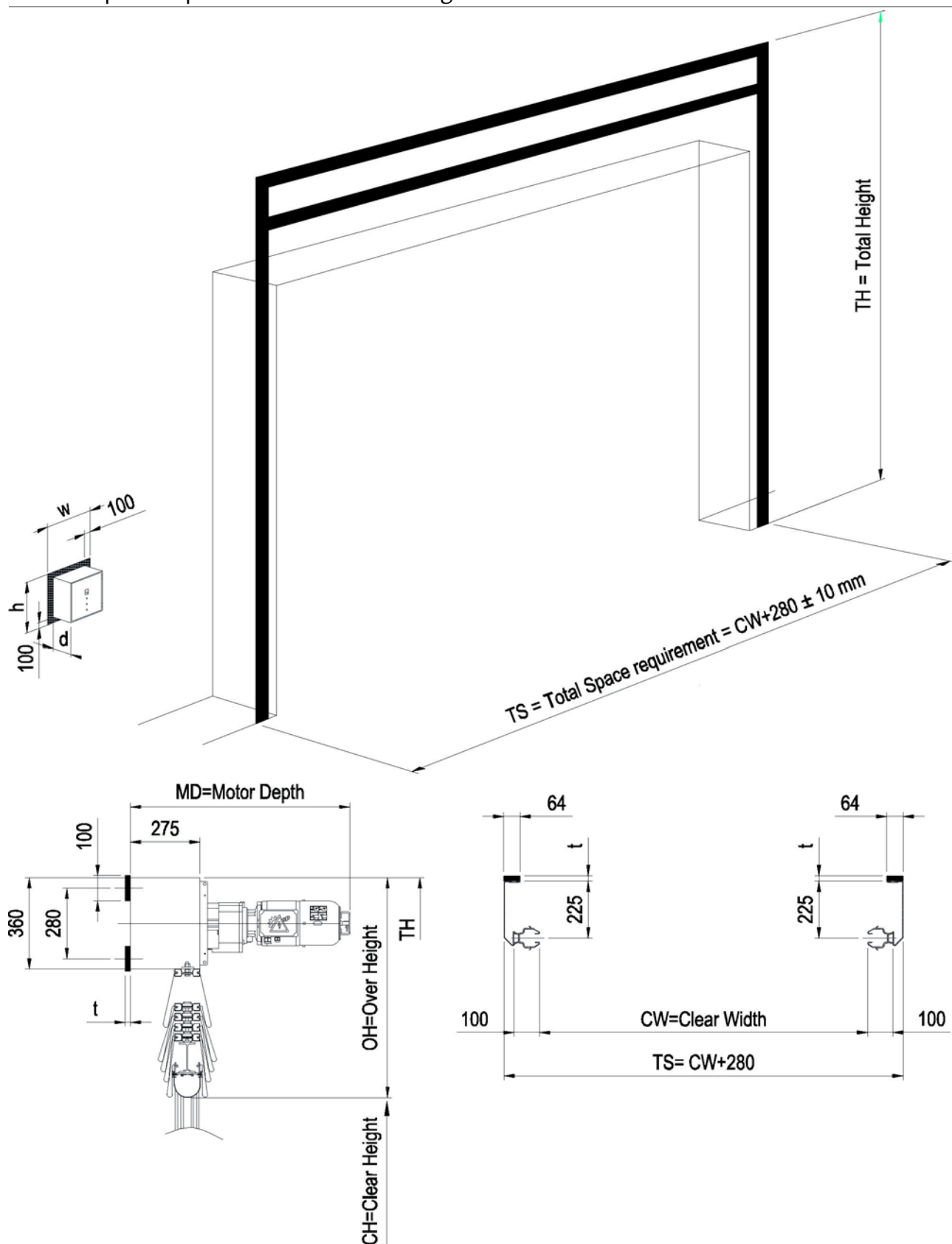

Note: Mounting is possible inside and outside the building.

4.2.5 Space requirements - Installation against wall between columns

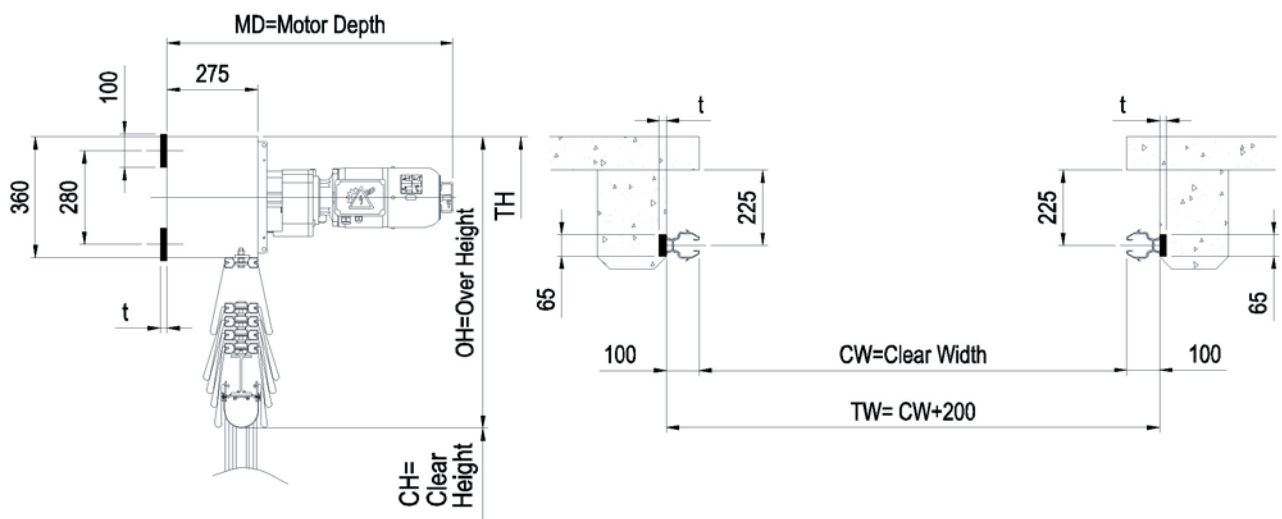
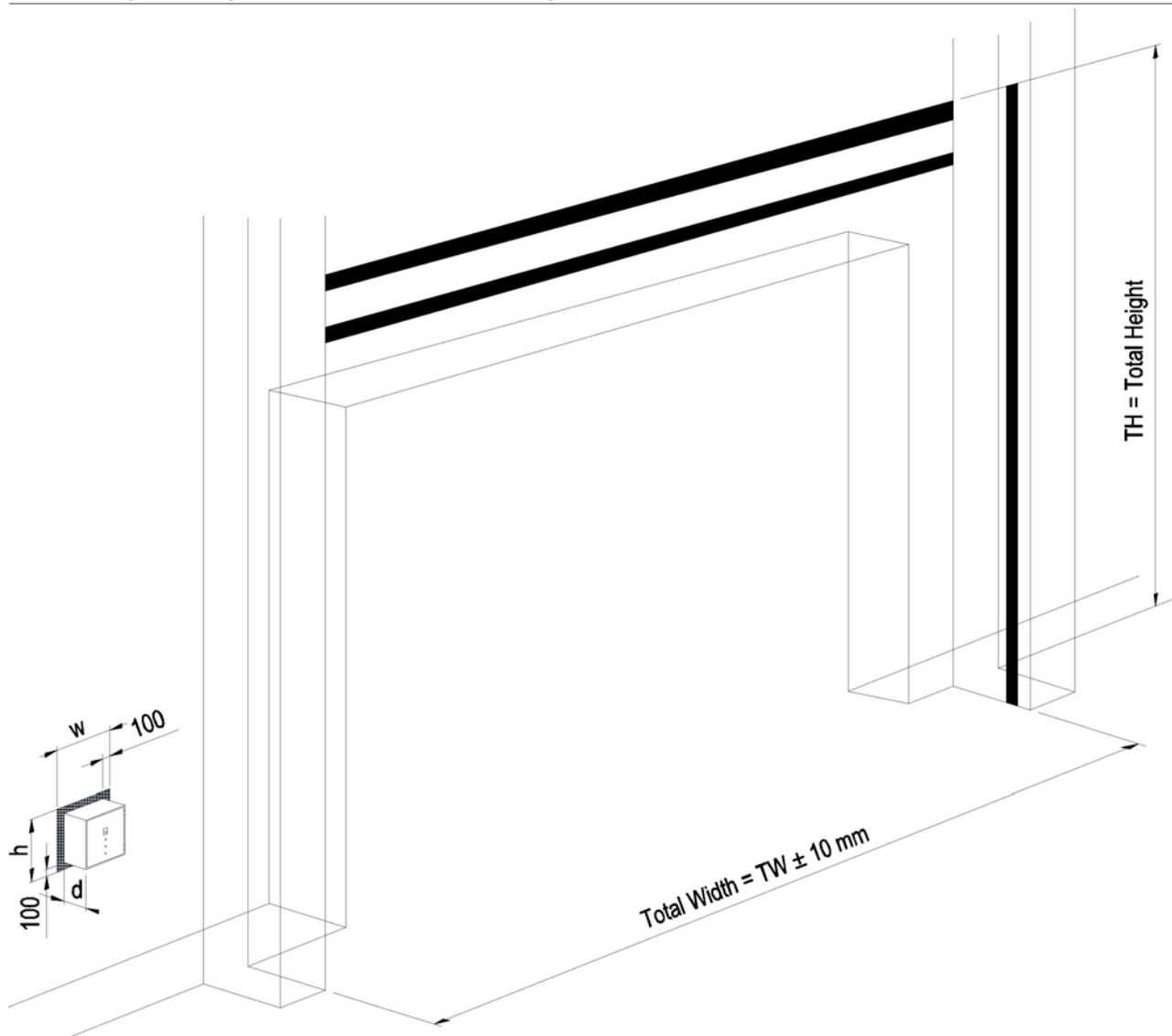

4.2.6 Space requirements - Installation with self-supporting header box

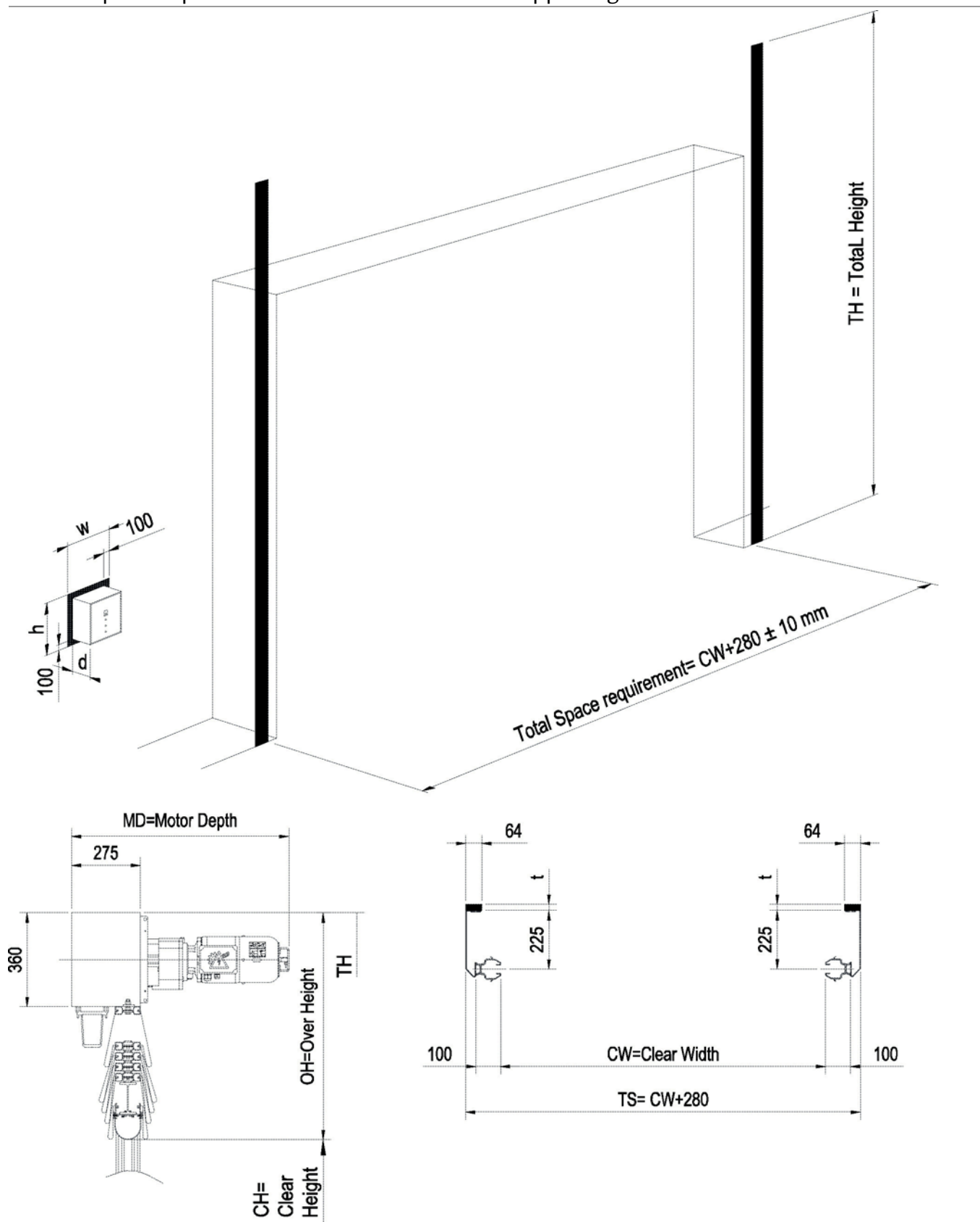

4.2.7 Space requirements - Installation in door opening

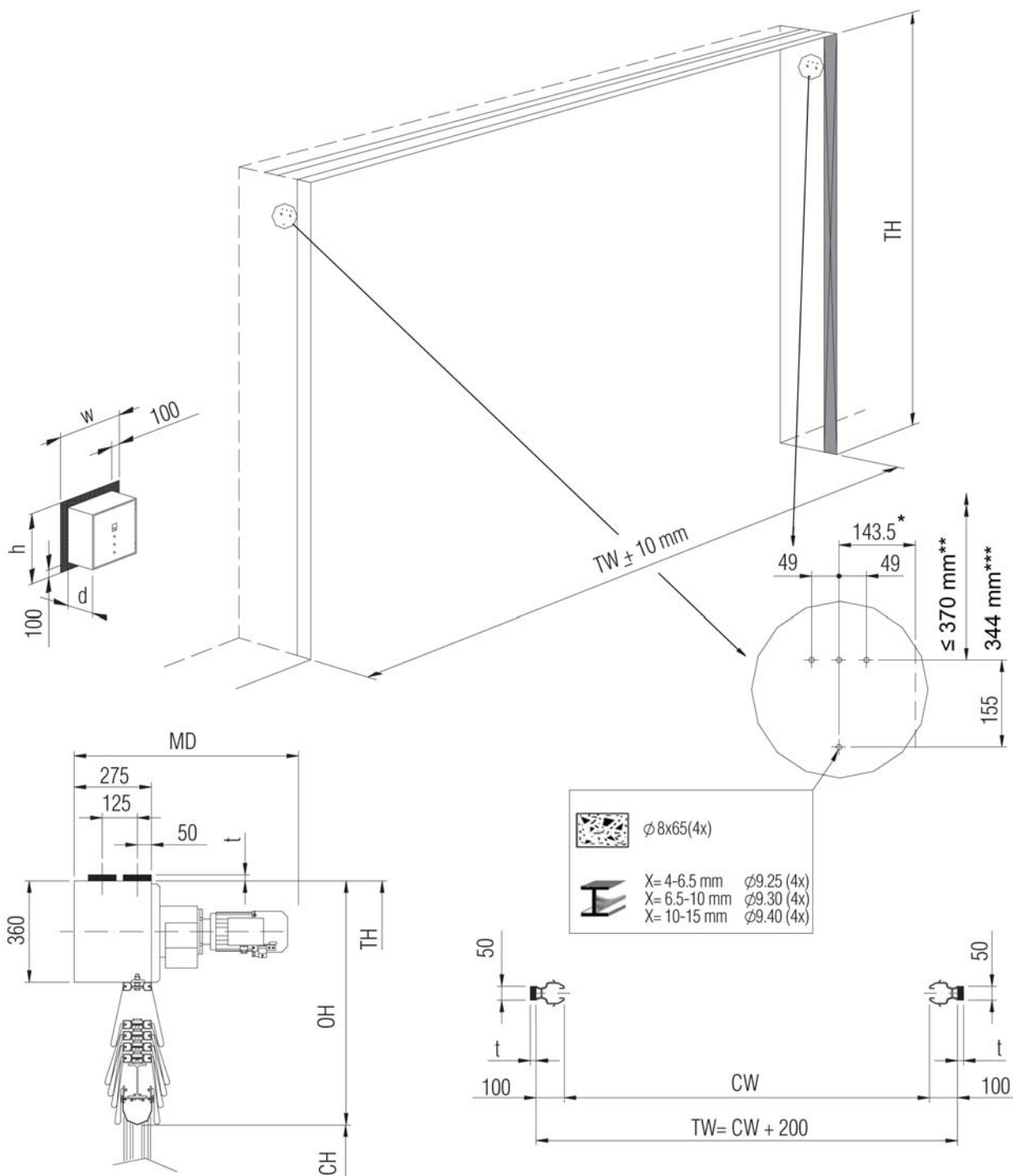

The VL3110 vertical lifting fabric door can also be provided with a self-supporting header box. The upper fixing surfaces are then replaced by surfaces for securing brackets.

- * distance to door leaf centre line
- ** minimal clearance
- *** distance to top of header box

5. Service

Preventive Maintenance Program and Modernization Services

As your entrances are part of your business flow, there's every reason to keep them working well. ASSA ABLOY Entrance Systems offers you a maintenance and modernization expertise to rely on. Our Maintenance Programs and Modernization Services are backed by a extensive expertise for all types of industrial door and docking systems, independent of brand. At your disposal is a team of dedicated expert technicians, proven through decades of maintenance, service and satisfied customers.

Preventive Maintenance Programs

Minimizing lost time, lost energy and unexpected hassle is our team's constant objective. Our service organization can support you 24/7 in maintaining all industrial door and docking systems, independent of brand. If you want to be one step ahead of break-downs, explore our portfolio of Pro-Active Care plans. Naturally, we also offer entrance upgrades to suit your specific wishes and business needs.

Pro-Active Care - Maintenance plans to fit your business

Regular maintenance can extend the lifetime of your equipment and help prevent unexpected problems. Our technician arrives on-site equipped with the knowledge and tools to service all automatic entrances, independent of brand.

- **Pro-Active Bronze**

The base on which all Pro-Active Plans are built provides the security of knowing that your equipment is regularly inspected and certified for safety, as well as performing optimally. It includes a number of planned on-site visits depending on your needs. Any unplanned service calls required during the term of the contract (including labor, travel and parts) are billed at special Pro-Active Care prices.

- **Pro-Active Silver**

This plan provides all the benefits of Pro-Active Bronze with the added advantage of labor and travel being included for service calls during regular business hours. The only additional charge would be for any parts that may be needed throughout the term of the contract.

- **Pro-Active Gold**

This plan provides the ultimate protection for your automatic entrance investment. It includes all the benefits of Pro-Active Silver, plus replacement of any parts required during an unplanned repair or planned maintenance visit. Pro-Active Gold is an excellent way to budget your automatic door expenses annually.

- **Pro-Active Tailor-Flex**

Our most flexible maintenance and service offering. The Pro-Active Care plan is designed by you, our customer. The plan allows you to balance your maintenance expenses against your real-world budget and presents the option to add or delete a number of maintenance elements to suit your budget goals, while meeting your overall performance and safety needs.

Modernization

Your entrances are a long-term investment, from which you always want the best. Products develop over time, so do regulations and your business. Let us help you increase energy savings and meet today's standards. We provide advice and modernization kits for outdated installations, ensuring your investment meet requirements and performs optimally for many more years to come.

Re-Active Service		Pro-Active Care				
		Pro-Active Bronze	Pro-Active Silver	Pro-Active Gold	Pro-Active Tailor Flex	
		○	○	○	●	Other customized requests such as Response Time, Performance InfoPack and Advanced User Training
		○	○	●	○	Replacement of worn parts according to preventive Consumable Exchange Program
		○	○	●	○	Replacement of spare parts on breakdowns
		○	●	●	○	Travel and labor for additional call-out visits
		●	●	●	●	Preventive maintenance visits 1-4 times per year
		●	●	●	●	Travel and labor for preventive maintenance visits
		●	●	●	●	Response time and priority on call-outs <24h
		●	●	●	●	Preventive planned maintenance that meets the most demanding standards in the market
	●	●	●	●	●	Safety and quality checks according to applicable regulations and norms. Documentation of test results provided
●	●	●	●	●	●	Documentation of equipment status, assessment and service provided, all generated on site
●	●	●	●	●	●	Highly trained professional technicians with extensive knowledge, state-of-the-art tools and the right spare parts*
●	●	●	●	●	●	Dedicated Professional Customer Care Hotline

● = Included as standard
○ = Available at special prices

* Well-stocked service vehicles with genuine and new spare parts

Index

A		P	
Access and automation	12	Performance	3
Acoustic insulation	22	Photocell	13
Acoustic signal	14	PLC	12
Additional functions	14	Protective casing for motor	10
Air permeability	21	Pull-rope switch	13
Arctic fabric	17		
Automatic closing	13	R	
Automatic control functions	13	Radar	13
Automatic opening and closing	13	Reduced opening	12
		Remote control	13
B		Resistance to water penetration	21
Basic control functions	12	Resistance to wind load	21
Basic installation	23, 27		
Belt system	11	S	
Bottom section	7	Safety arresters	7
Building and space requirements	23	Safety edge	12
Building preparations	23	Safety functions	14
		Safety photocells 1-channel	14
C		Safety photocells 2-channel	14
CEN Performance	21	Security fabric	20
Clear width and clear height	15	Self-supporting header box	11
Colors	8	Self-supporting installation	25
Construction	7	Service	35
Control unit	12	Sound reduction fabric	18
Copyright and Disclaimer Notice	2	Space requirements	29
		Space requirements - Installation against wall	31
D		Space requirements - Installation against wall between columns	32
Description	6	Space requirements - Installation in door opening	34
Door leaf	7, 16	Space requirements - Installation with self-supporting header box	33
		Space requirements for control unit	30
E		Space requirements for maintenance 30	
Electrical operation	11	Space requirements for operation	29
Emergency power switch	14	Specifications	15
Environmental tolerance	15	Stainless steel cladding and motor casing	10
Extension jamb	10, 28	Standard	6
External control functions	13	Standard colors	8
External push button box	13	Standard fabric	16
		Surface treatment	15
F			
Fabric data	16		
Features	3		
G			
Gear motor	11		
General	6		
General specifications	20		
Guide rails	9		
H			
Header box	10		
Header box options	10		
Heat resistant fabric - Aluminium coating	19		
Heat resistant fabric - Aluminium polyurethane coating	19		
Heat resistant fabric - Silicone rubber coating	18		
Hold-to-run control	12		
I			
Increased opening speed	14		
Installation of the control unit	28		
Installation of the guide rails	27		
Installation of the header box	23		
Installation with jambs	27		
Interlocking	12		
Intermediate section	7		
J			
Jambs	9		
L			
Lifetime expectation	21		
Limit switch boxes	11		
Load on the building	24		
M			
Magnetic loop	13		
Material	8		
Mounting surfaces for guide rails	26		
N			
Non-motor side covered	10		
O			
Operating forces and safe openings	22		
Operating system	11, 20		
Optional colors	8		
Options	6, 8		

T

Technical facts	3
Temperature control	12
Thermal transmittance	22

V

Vision panels	20
---------------------	----

W

Warning lights - Green	14
Warning lights - Orange flashing lights 14	
Warning lights - Red	14
Wind deflectors	10

ASSA ABLOY Entrance Systems is a leading supplier of entrance automation solutions for efficient flow of goods and people. With our globally recognized product brands Besam, Crawford, Megadoor and Albany, we offer products and services dedicated to satisfying end-user needs for safe, secure, convenient and sustainable operations.
ASSA ABLOY Entrance Systems is a division within ASSA ABLOY.

ASSA ABLOY

assaabloyentrance.com



ASSA ABLOY Entrance Systems

assaabloyentrance.com